

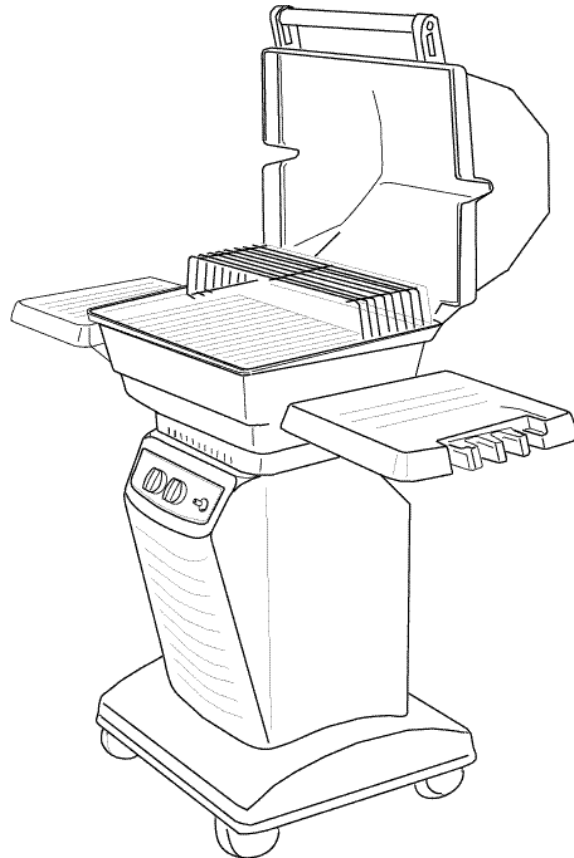

Assembly and Owner's Manual

Model 4000 Series Portable Gas Grill



ASSEMBLER / INSTALLER:

Leave these instructions with the consumer .

CONSUMER / USER:

Read all of these instructions and keep them in a safe place for future reference.

FOR YOUR SAFETY

If you smell gas:

- 1 Shut off gas to the appliance.
- 2 Extinguish any open flame.
- 3 Open lid.
- 4 If odor continues, immediately call your gas supplier or fire department.

FOR YOUR SAFETY

- 1 Do not store or use gasoline or other flammable vapors and liquids in the vicinity of this or any other appliance.
- 2 An unconnected liquid propane cylinder should not be stored in the vicinity of this or any other appliance.

Statement of Commitment

Congratulations and thank you for your purchase of the Great Outdoors gas grill. We are pleased that you have recognized the value of the design, function, and quality of components used in this product. We believe it is the finest grill on the market.

We are committed to producing quality grills that your family will enjoy for years to come. If you are not satisfied with your new grill for any reason, you can call this toll-free number at any time:

888-869-5454

We want you to be completely satisfied with your purchase so you will agree with our motto,
*“there’s nothing like...
the great outdoors.”™*

the Great Outdoors Grill Company ®
7980 East American Drive
Joplin, Missouri U.S.A. 64804

For more information about our growing family of barbecue grills visit our internet site at:

www.gogrills.com

Table of Contents

	Page Number
Chapter One - INSTALLATION	4
Necessary Information	4
Choosing a Safe Location	4
Portable L.P. Gas Grills	5 - 7
Important Features of the Series 4000 LP Gas Grill	8
L.P. Gas Dealer Instructions	9
Chapter Two - ASSEMBLY INSTRUCTIONS	10
Identifying Parts	11
Attach Pillar to Grill Bottom	12 - 13
Assemble Base to Pillar	14 - 15
Install X-Brace	16 - 17
Install the Side Tables	18 - 19
Assemble Grill Lid	20 - 21
Installing the Internal Parts	22 - 23
Installing an L.P. Gas Cylinder	24
Connecting an L.P. Gas Cylinder	24 - 25
Chapter Three - USE and CARE DIRECTIONS	26
Leak Testing	27
Lighting Instructions	28 - 29
Using Your Grill	30
Cleaning and Maintenance	31 - 33
Replacement Parts	34 - 35
Chapter Four - OUTDOOR COOKING / RECIPES	36
Recipes	36 - 39
Warranty	40

1st printing Sept. 2001 ©
2nd printing Jan. 2002 ©

The Great Outdoors Grill Company® logo is a Registered Trademark of the Great Outdoors Grill Company® and not to be used without express permission by the owners and managers of the Great Outdoors Grill Company®.
Patents Pending
USA1998 - 2002.

Model 4000 Series

Installation Chapter 1

Necessary Information to Safely Use a Gas Grill.

The gas fuel used by this product is highly flammable and must be used in a responsible and cautious manner.

It is your responsibility to assemble, operate, and maintain your gas barbecue grill properly.

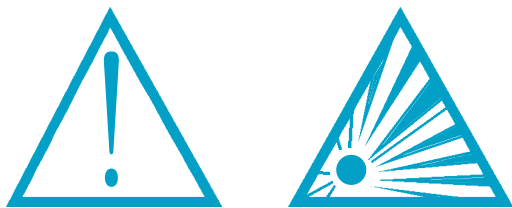

If these instructions are ignored, there is a possibility of a hazardous fire or explosion which could result in property damage, physical injury or death.

Choosing a Safe Location for a Gas Barbecue Grill.

1. The gas barbecue grill may only be used for cooking out-of-doors.

- Do not operate this barbecue in garages, breezeways, sheds or any enclosed area.

- Operating this or any gas-fired appliance in an enclosed area can produce a build-up of carbon-monoxide, which could result in injury or death.

2. Installation must conform with local codes or, in the absence of local codes, with either the National Fuel Gas Code, ANSI Z223.1, NFPA 54 (USA), or CAN/CGA-B 149.2, Propane Installation Code (Canada) and CAN/CGA-B 149.1 Natural Gas Installation Code.

To check local codes, contact your local gas dealer or gas company listed in the Yellow Pages for recommended installation procedures and regulations.

3. This appliance is not intended to be installed in or on a recreational vehicle and/or boat.

4. Keep the barbecue grill at least 24 inches (61 cm) away from any combustible construction.

- Do not use a grill under a ceiling or cover where the heat or flame could cause damage.

- Choose a level surface where the grill is not facing directly into the wind.

- Avoid moving the grill during use.

5. The grill area must be clear and free from combustible materials, gasoline, and any other flammable liquids or vapors.

- Do not use lighter fluid or charcoal briquettes in a gas grill. The flow of combustion and ventilation air is not to be obstructed.

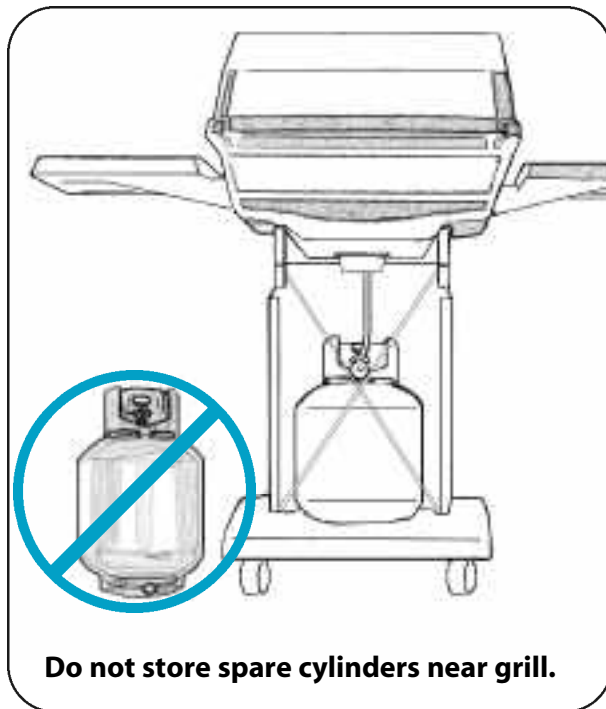

- The ventilation openings of the cylinder enclosure must be kept free and clear from other debris.

6. Do Not store a spare L.P. gas cylinder under or near this appliance.

- Do not store an L.P. cylinder in a building, garage or any other enclosed area. Instead, store the cylinder outdoors in a well ventilated area, away from people and out of the reach of children.

7. NOT FOR USE BY CHILDREN.

- Place your barbecue grill in a location away from children and pets.
- Do not leave grill unattended when in use.

8. The outside of the barbecue grill will become hot during use.

- To avoid burns, do not touch any hot grill surface. If necessary, use a protective glove when operating control knobs, tank shut-off valve, or lid handle.

- Do not place combustible material, such as cloth or plastic, on grill surface during use.
- Do not lean on side tables or place more than 15 pounds of weight on a side table.

9. Make sure that the heat shield and drip pan are in place under the grill bottom.

- Heat and hot drippings from cooking food could damage the fuel supply system.

Portable L. P. Gas Barbecue Grills

WARNING: Do not use natural gas in an appliance designed for L.P. gas. Use only liquid propane (L.P.) gas in an appliance designed for L.P. gas.

L.P. Gas

Liquid Propane (abbreviated L.P.) gas is stored under high pressure inside a cylinder and will vaporize when released. It is important that there are no leaky connections on the grill fuel supply system. Refer to the Leak Testing section of this manual.

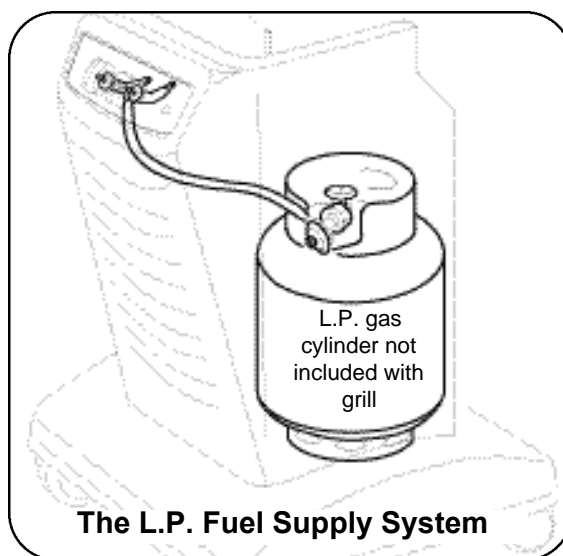

The L.P. FUEL SUPPLY SYSTEM

An L.P. gas grill requires a fuel delivery system made up of an L.P gas supply cylinder, a fuel regulator with hose and a gas-control valve.

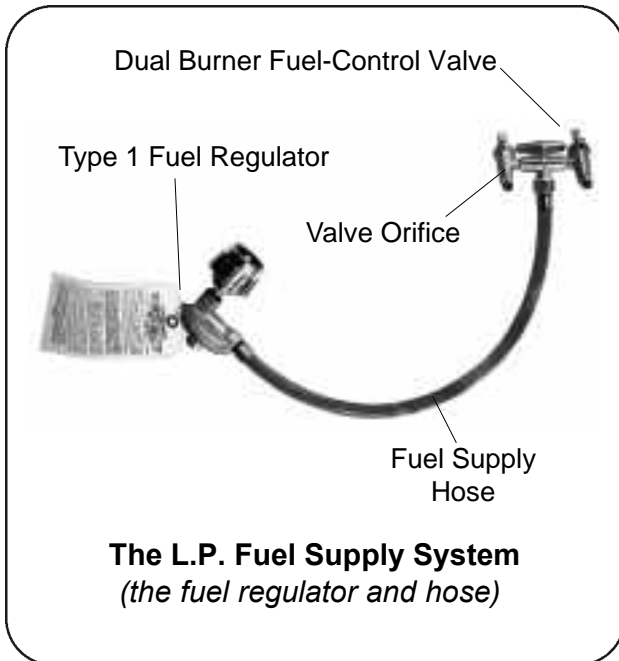

FUEL REGULATOR AND HOSE

The fuel regulator supplied is equipped with a Type 1 coupling nut. Do not attempt to connect to any other L.P cylinder not equipped with a mating Type 1 cylinder valve.

This grill is not to be used with any other cylinder connection device.

The fuel regulator and hose assembly with the Type 1 fitting supplied must be used with the appliance. Do not use a hose and regulator assembly other than the one supplied with the grill or a manufacturer's replacement fuel pressure regulator assembly.

The Type 1 connection system has the following features:

1. The system will not allow gas to flow until a positive connection has been made.

2. The system has a thermal element that will shut off the flow of gas between 240° F and 300° F.

3. The system has a flow-limiting device which when activated, will limit the flow of gas to 10 cubic feet per hour.

4. The pressure regulator and hose assembly provided is factory set at an outlet pressure of 11 inches water column (.4 lb. per sq. inch).

WARNING: Any attempt to adjust the regulator is dangerous and could create a situation causing personal injury or property damage. Consult your L.P. gas dealer if you think the regulator is not working properly.

L.P. GAS SUPPLY CYLINDER

NOTE: AN L.P. CYLINDER IS NOT INCLUDED WITH THIS GRILL MODEL.

An L.P. cylinder can be obtained at the store where you purchased your grill or from an authorized L.P. gas dealers.



L.P. GAS CYLINDER SPECIFICATIONS

Any L.P. gas-supply cylinder used with this grill must be approximately 12 inches diameter and 18 inches high. The maximum fuel capacity must be 20 pounds of propane. Full-cylinder weight should be approximately 38 pounds (43.7 lbs. nominal water capacity).

The L.P. cylinder must have a shut-off valve terminating in a Type 1 L.P. gas-cylinder-valve outlet. A Type 1 compatible cylinder with a Type 1 cylinder valve has a positive seating connection that does not permit gas flow until a positive seal has been obtained.

The cylinder must be arranged for vapor withdrawal. It must also include a Collar to protect the cylinder valve. A safety-relief device having direct communication with the vapor space of cylinder must be provided. This will expel high-pressure gas if the cylinder is overfilled or overheated.

All L.P. gas cylinders used with this appliance shall be constructed and marked in accordance with the specifications for L.P. gas cylinders of the U.S. Department of Transportation (DOT) or the National Standard of Canada, CAN/CSA-B339, Cylinders, Spheres and Tubes for Transportation of Dangerous Goods; and Commission, as applicable; and shall be provided with a listed overfilling-prevention device. Read labels on the L.P. gas-supply cylinder.

DANGER: Do not insert any foreign objects into the valve outlet. You may damage the back check. A damaged back check can cause a leak, which could result in explosion, fire, severe personal injury, or death.

Allow only a qualified L.P. gas dealer to fill or repair an L.P. gas-supply cylinder.

Inform the gas dealer if it is a new or used cylinder to be filled. Caution the gas dealer not to overfill the fuel cylinder.

After filling, have the gas dealer check for leaks and that the relief valve remains free to function.

Have the gas dealer weigh cylinder after filling to ensure that the cylinder is not overfilled.

DANGER:

a.) Do not store a spare L.P. gas cylinder under or near this appliance.

b.) Never fill the gas cylinder beyond 80 percent full.

c.) If the information in “(a.)” and “(b.)” is not followed exactly, a fire causing death or serious injury may occur.

TRANSPORTING A FULL CYLINDER

WARNING! Handle a full cylinder with care. Gas is under high pressure.

You should transport only one cylinder at a time. Transport the cylinder in an upright and secure manner with control valve turned off and the POL plug in place.

Do not transport cylinder in the passenger compartment of a vehicle.

Do not leave cylinder in direct sunlight or in a high-heat area such as a closed car trunk. High-heat areas could cause the relief valve to vent gas.

Use a cylinder cap on cylinder-valve outlet during transport and when the cylinder is not connected to grill. Keep cylinder valve closed when not in use.

Important Features of Series 4000 L.P. Gas Grills

HEAT SHIELD, GASKETS AND COLLAR

WARNING! Do not remove the heat shield, gaskets, collar assembly from the grill bottom.

Operating this grill without the heat shield, gaskets, collar assembly attached to the grill bottom would result in a hazardous situation which could cause serious damage to property and possible physical injury.

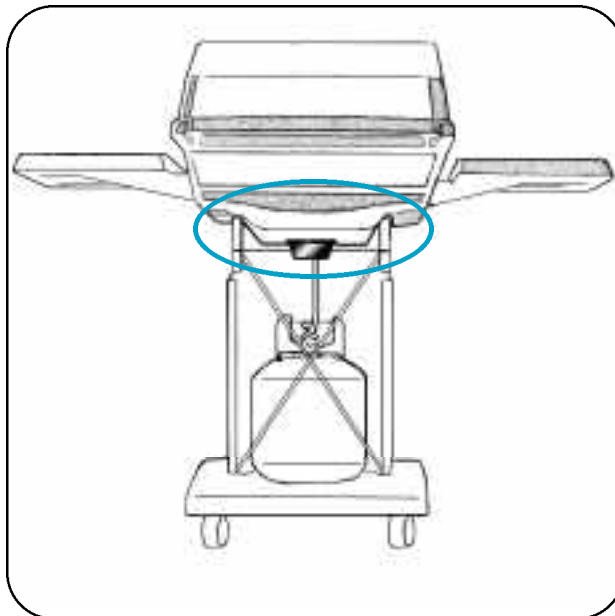

Rear view of Series 4000 grill with the heat shield, gaskets, collar assembly.

X-BRACE RETAINER WIRE

It is important to properly fit the X-Brace retainer wire inside the pillar to provide additional stability. Remove the X-Brace only when installing an L.P. gas supply cylinder.

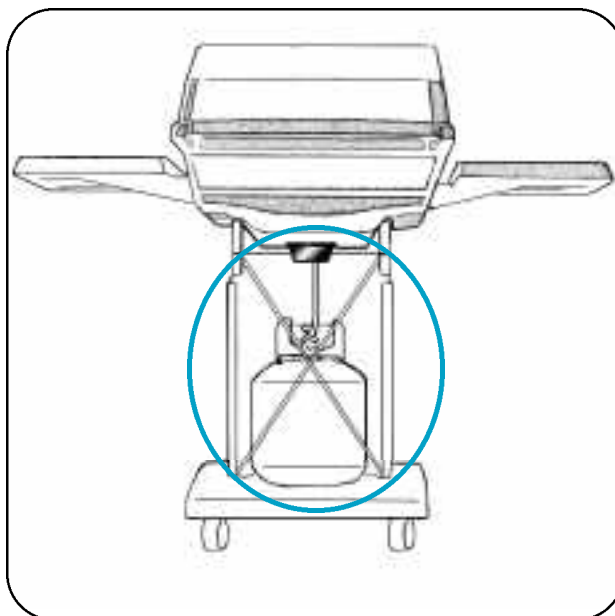

Rear view of Series 4000 grill with the X-Brace retainer wire shown in place.

Take These Instructions to the L.P. Gas Dealer.

When using a cylinder exchange, be sure the exchanged cylinder is a Type 1 cylinder; a 510 POL cylinder will not fit a Type 1 regulator.

FILLING AND PURGING TYPE 1 L.P. GAS CYLINDERS

DANGER! Purging and filling of L.P. Gas cylinders must be performed by personnel who have been thoroughly trained in accepted L.P. gas industry procedures. Failure to follow this instruction may result in explosion, fire, severe personal injury, or death.

IMPORTANT: Purge new cylinders before filling. This tank is easily filled with a standard CGA 510 POL filling connection.

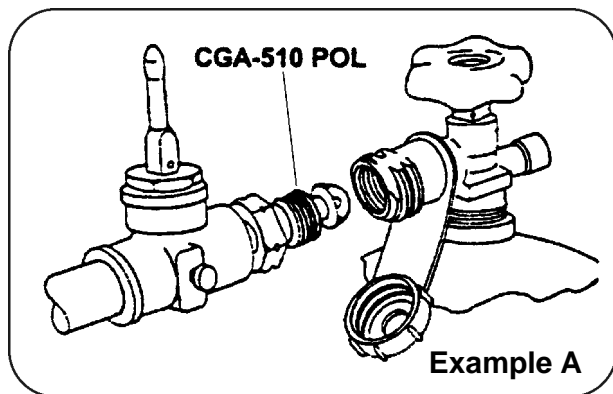

Filling a Type 1 Cylinder Valve

*Example A: shows a CGA-510 POL fitting.
Example B: shows using a Type 1 POL fitting.*

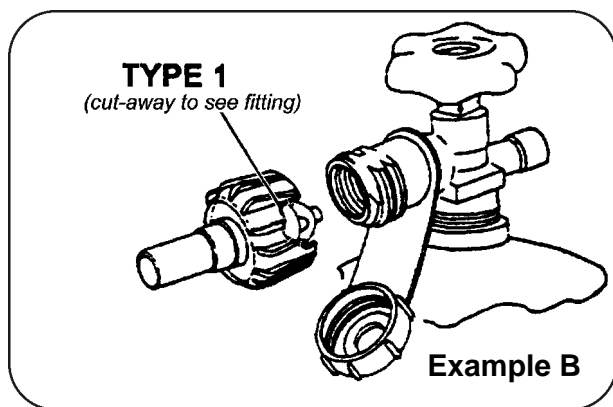

The L.P. gas cylinder has a Type 1 cylinder valve with a back-check module in its outlet that will not permit gas to flow until an evacuation device is installed. To purge the L.P. gas cylinder, the back-check module must be opened with an evacuation device.

PURGING AND EVACUATION DEVICES FOR L.P. GAS CYLINDER WITH TYPE 1 CYLINDER VALVES

A. Hose-end valve with a bleed port: Purging can be accomplished using a hose-end valve containing a bleed port, which also allows for evacuation without the use of an adapter.

B. Hose-end valve without a bleed port: When a hose end valve does not have a bleed port, a separate device must be used for evacuation.

C. Purging using a Type 1 connection: L.P. gas cylinder evacuation can be accomplished during each purging by using a Type 1 connection. The Type 1 valve outlet has 1 5/16" external ACME right-hand thread that will accept this connection.

CAUTION: After purging or filling an L.P. gas cylinder, do not insert a POL plug into the valve outlet. Insertion of this plug will prevent the back-check from closing. Use **ONLY** the provided cap and strap attached to the outlet. Close the cylinder valve knob before returning the cylinder to the customer.

For proper purging procedures in the U.S.A. refer to: Safety Bulletin NPGA #133, "Purging L.P. Gas Cylinders," and Safety Bulletin NPGA #130, "Recommended Procedures for Filling Cylinders."

DANGER: Do not fill an L.P. gas cylinder beyond 80% full. If this information is not followed exactly, a fire causing serious injury or death may occur.

Model 4000 Series

Assembly Instructions Chapter 2

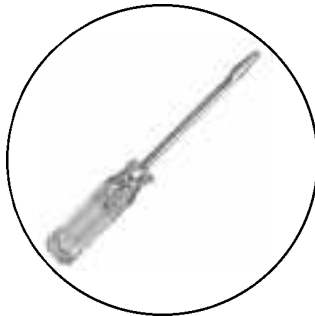

Getting Started

1. Please follow the steps in the order that they are presented.
2. Assemble the grill where you plan to use it.
3. You may want to place an old towel or cloth at the assembly site to prevent nuts and bolts from becoming lost.
4. Have a friend help. An assistant can make the assembly easier by holding the parts in place while you fasten the nuts and bolts.
5. To be ready to barbecue immediately, obtain a filled L.P. gas cylinder from an authorized L.P. dealer or cylinder exchange center.

Unpacking the Grill Parts

1. Remove and set aside all inner boxes and parts from the master carton.
2. Remove and set aside all wrapping paper and additional packaging from the parts.
3. Do not destroy carton or packing until your grill is completely assembled and operating to your satisfaction.

Tools needed to assemble grill:

- 3/8" open-end wrench*
- flat blade screwdriver
- 7/16" open-end wrench*

**HINT: A socket set or an adjustable wrench may be used instead.*

Assembly Instructions • Identify the Grill Parts

Locate these parts:

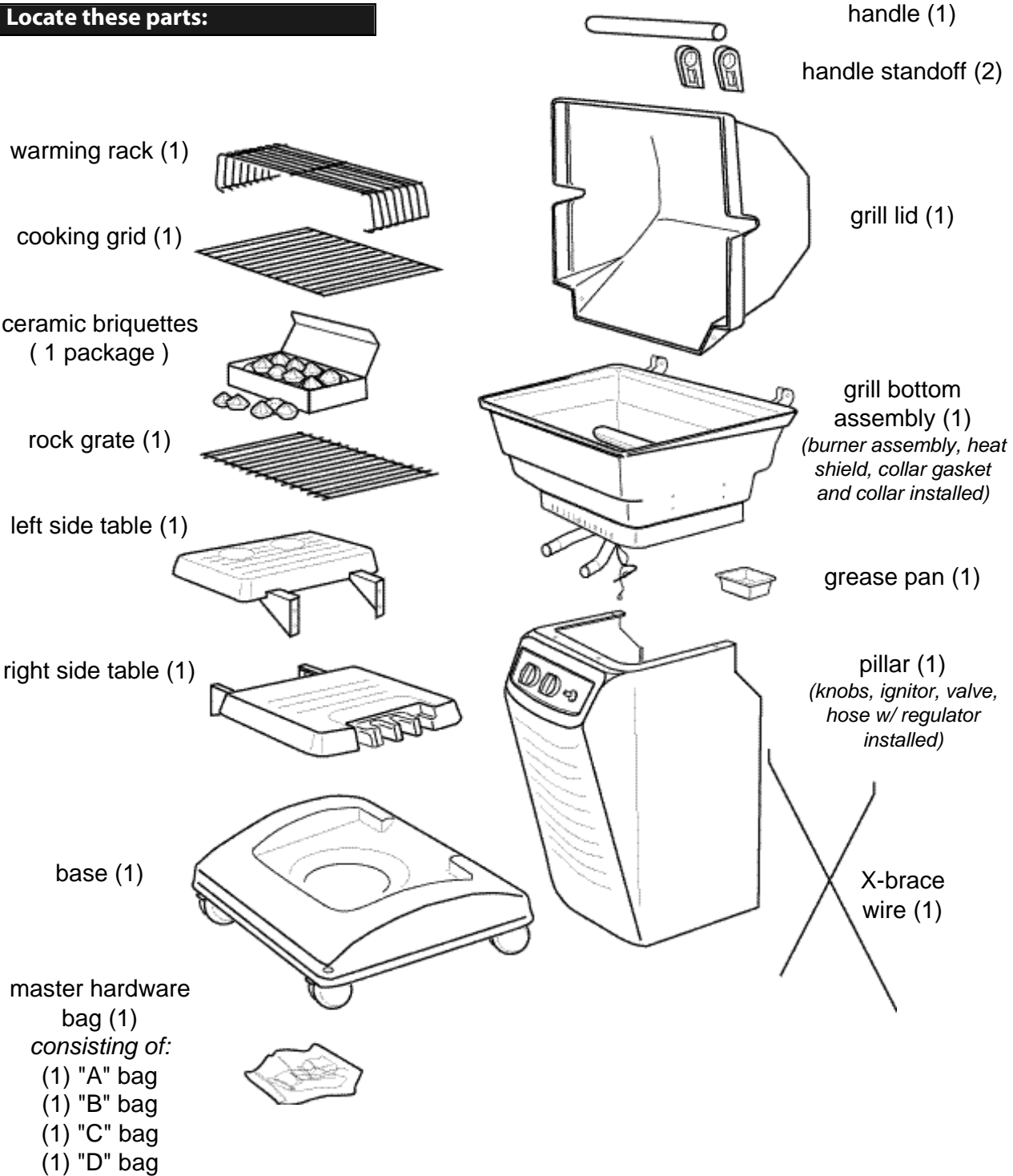

Assembly Instructions • Attach the Pillar to Grill Bottom.

tools needed:

$\frac{3}{8}$ " open-end wrench
flat-blade screwdriver

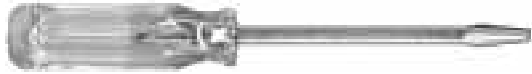

Use hardware bag "B":



1/4-20 x 3/4"
(4)

Locate these parts:

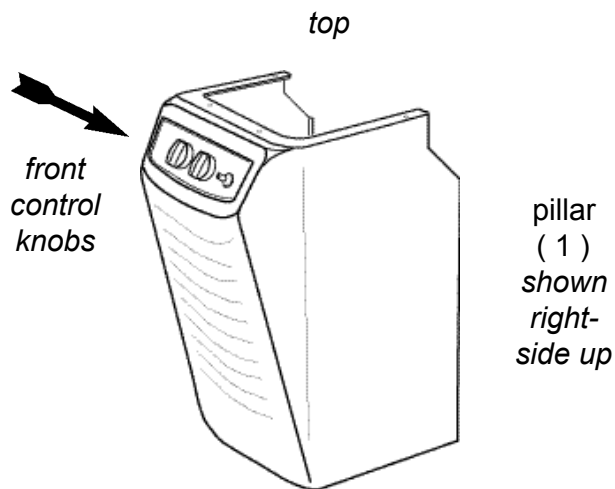
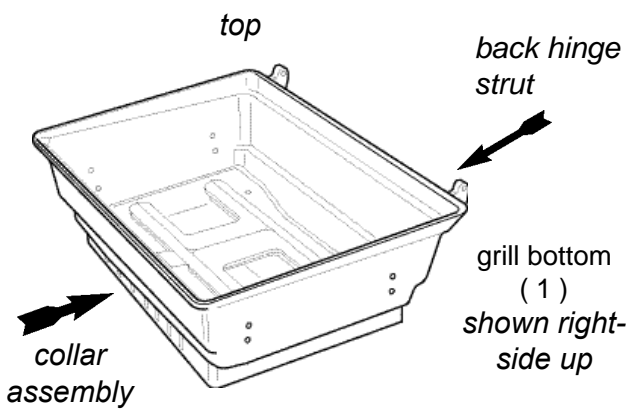

HINT: For the first portion of the assembly you will be assembling the grill bottom, pillar and base upside-down.

1. Position the grill bottom casting upside down so that the heat collar assembly is upward.
2. Working from the back (open) side of the pillar, set the pillar upside down onto the collar assembly.
3. Locate the holes in the pillar bottom and align with holes in collar.
4. **IMPORTANT:** Make sure the gas control valve ends are inside the burner venturi tubes extending through the grill bottom as shown. (See Adjacent Page)
5. Thread screws into holes and tighten with a wrench / screwdriver.

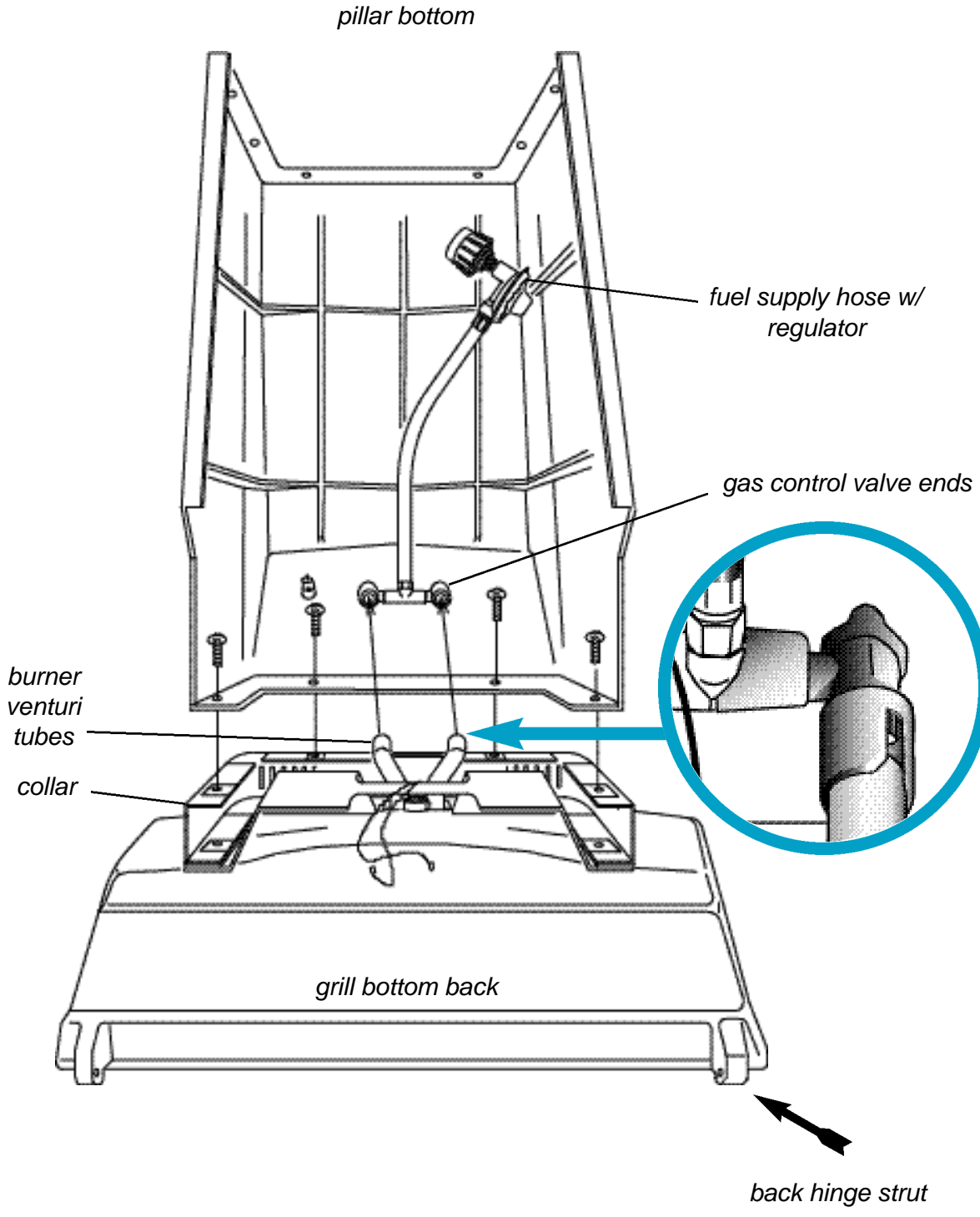

Assembly Instructions • Assemble Base to Pillar

tools needed:

$\frac{3}{8}$ " open-end wrench
 $\frac{7}{16}$ " open-end wrench



Locate this part:

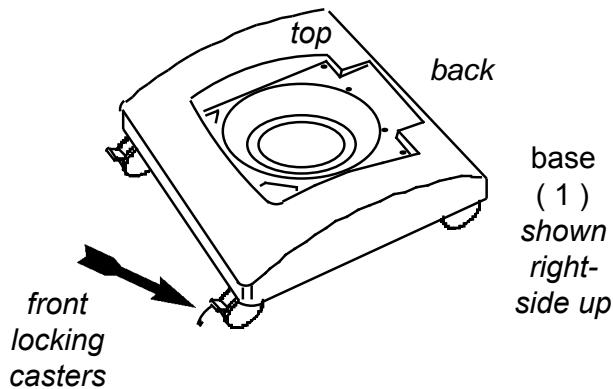

Use hardware bag "A":

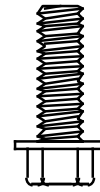

1/4-20 x 3/4"
(6)

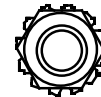

1/4-20
(6)

1. Lock the pre-assembled casters on base by pushing down on the latch.
2. Set the base upside-down on onto the pillar bottom as shown on the adjacent page, aligning holes in base with holes in pillar.
3. Insert six bolts through the holes in the pillar and base. Thread the locking hex nuts onto bolts. Tighten with a wrench and a flat-head screwdriver.
4. Locate the two black lead wires inside the grill bottom. Press the metal contacts of the loose ends of the lead wires onto the metal pins located on the base and side of the ignitor unit.

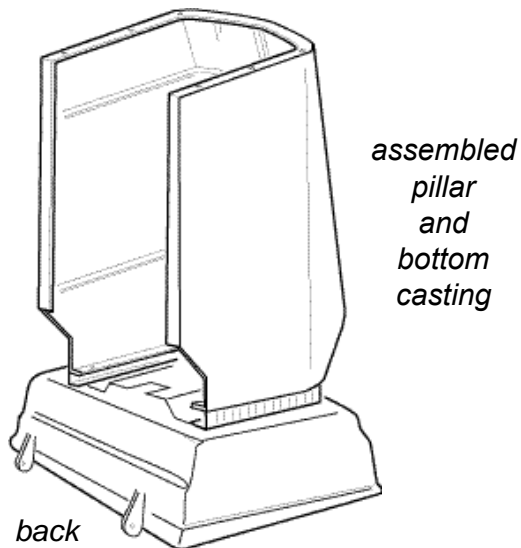

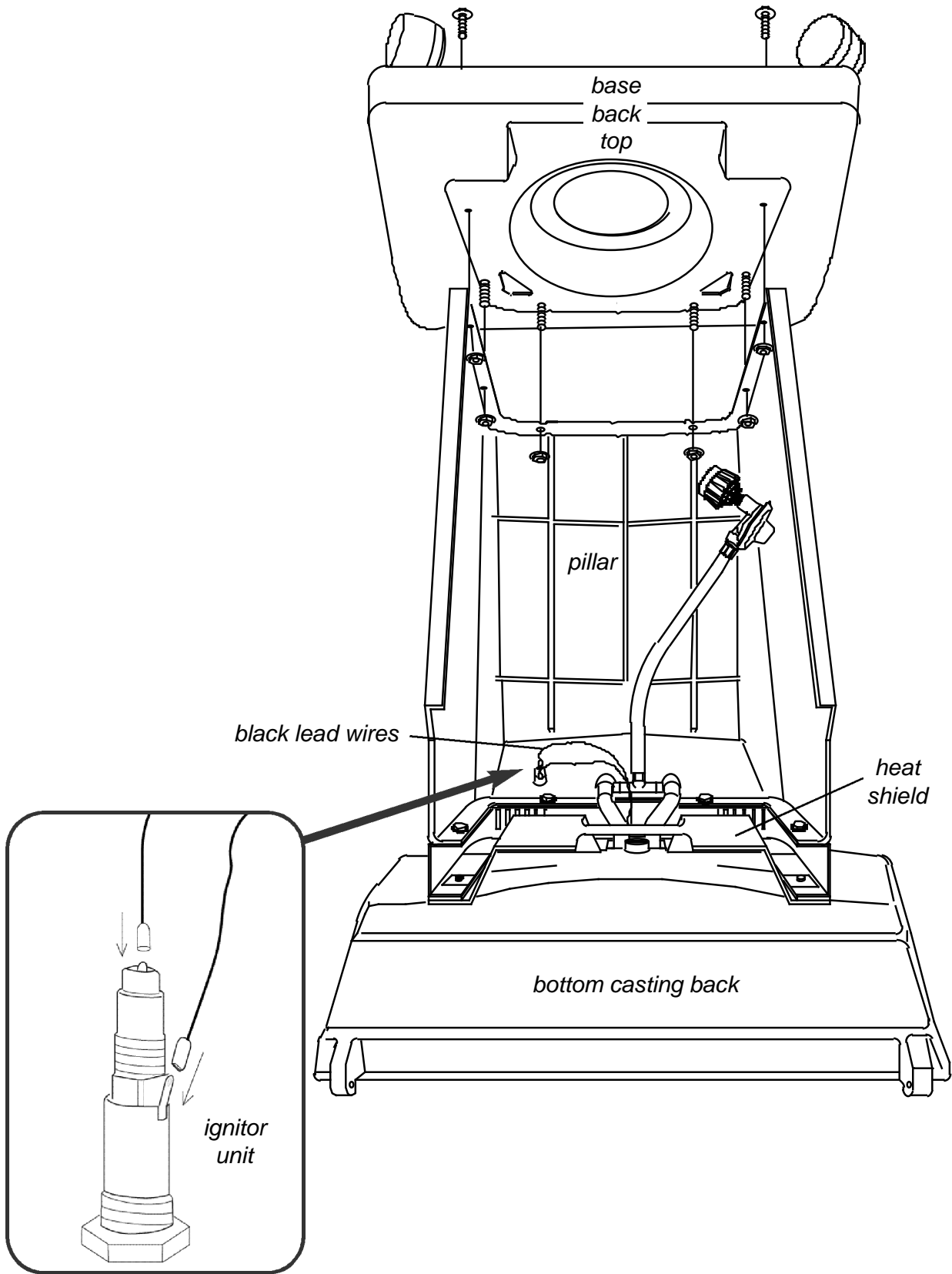

Assembly Instructions • Install X-Brace.

No tools needed.

Locate this part:

top bent
ends



X-brace
(1)

1 Now with the help of an assistant carefully turn the grill assembly right-side-up.

2. **IMPORTANT:**
Inspect beneath the grill bottom to check that the control-valve ends are still inside the burner venturi tubes.

The valve ends must always be inside the burner tubes for the grill to safely operate.

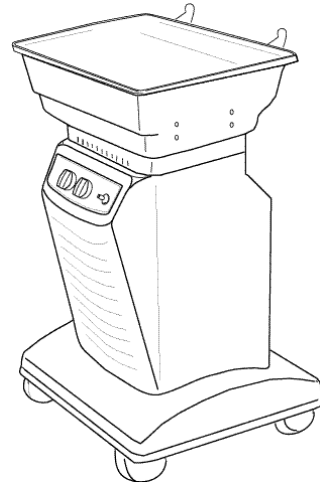

grill bottom as shown from below back.

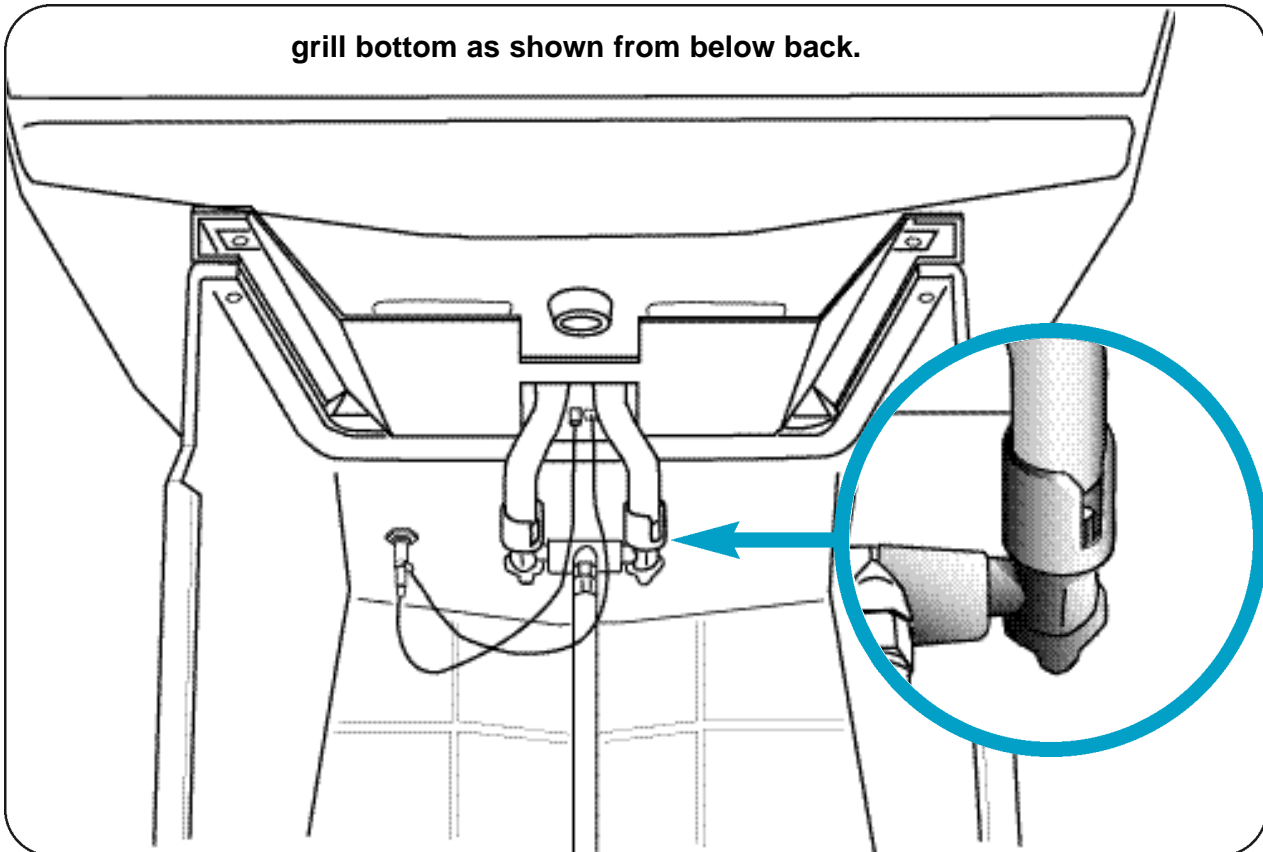

ATTENTION PRODUCT ASSEMBLER:

Install the X-brace retainer wire across the back of the pillar for warranty validation.

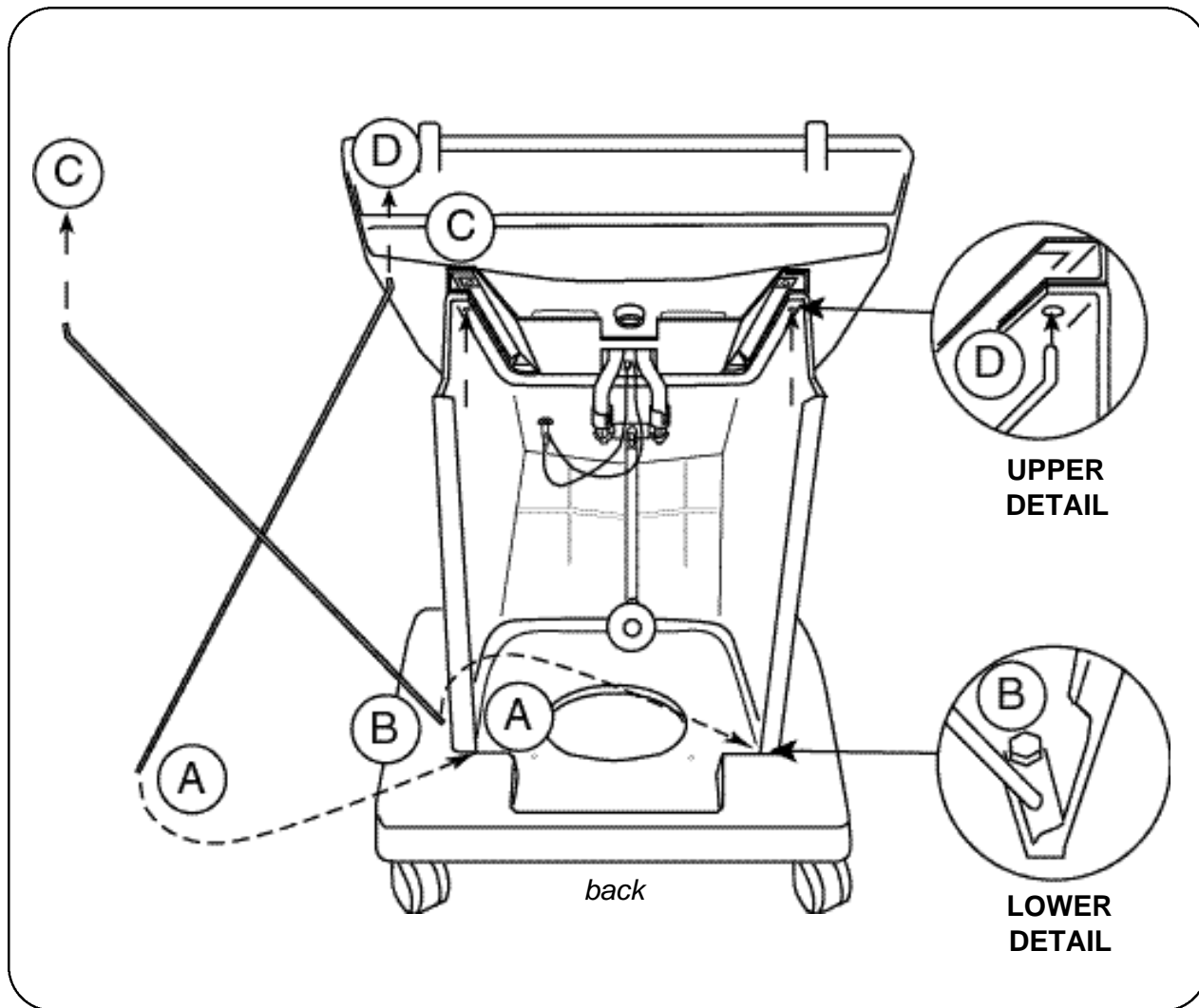

3. Position the wire ends "A" and "B" firmly into the pillar corners behind the bolt heads and against the base. (See Lower Detail.)
4. Complete the installation by snapping bent ends "C" and "D" into the two holes in the pillar. (See Upper Detail.)
5. When complete, the X-brace should be positioned as shown in the lower right picture.

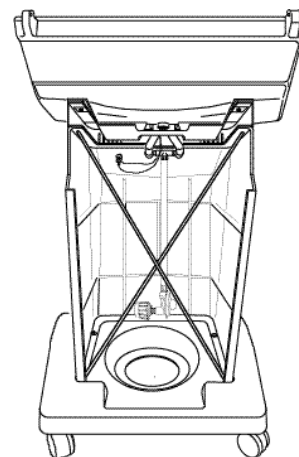

Assembly Instructions • Install the Side Tables.

tools needed:

3/8" open-end wrench

7/16" open-end wrench



Use hardware bag "C":

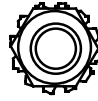

1/4-20
locking hex nut
(8)

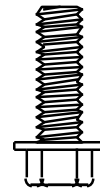

1/4-20 x 3/4" bolt
(8)

Locate these parts:

left side table
assembly (1)

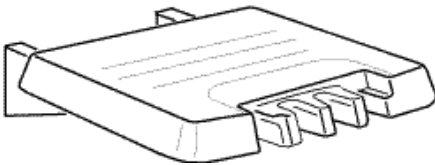
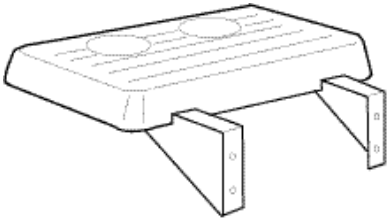

right side table
assembly (1)

1. Insert four 3/4" bolts through holes in the support brackets of the right side table assembly.
2. Attach the right side table to the four holes located in the right side of the grill bottom using the locking hex nuts provided.

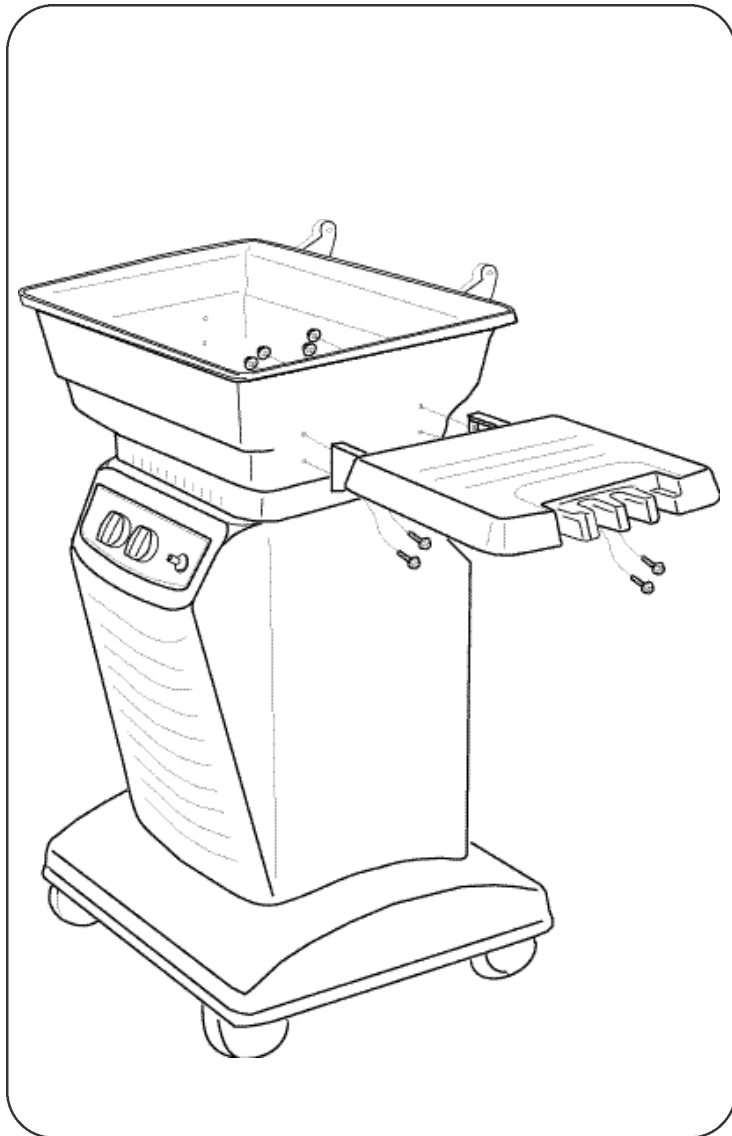



3. Insert four 3/4" bolts through holes in the support brackets of the left side table assembly.

HINT: Preformed hooks included on the right side table assembly may be used to keep cooking utensils (not included) at hand.

4. Attach the left side table to the four holes located in the left side of the grill bottom using the locking hex nuts provided.

CAUTION: Do not apply more than 15 pounds to either side table that could unbalance and tip the grill.

Assembly Instructions • Assemble the Grill Lid



tools needed:
7/16" open-end wrench
flat-blade screwdriver



use
hardware bag "D":

hairpin (2)

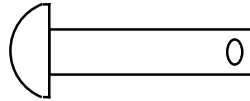

hinge pin
1/4 x 1 1/8"
(2)



1/4-20
hex nut (2)

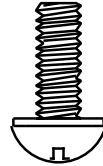

1/4-20 x 3/4"
bolt (4)

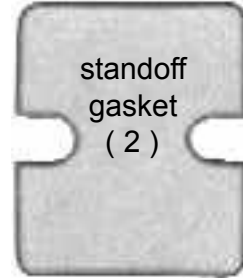

standoff
gasket
(2)

Locate these parts:

handle
(1)



handle standoff
(2)



grill lid
(1)

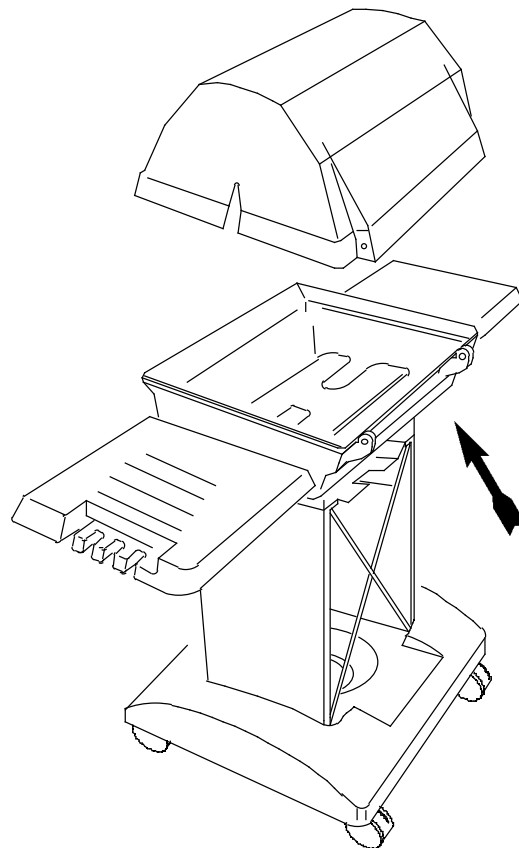
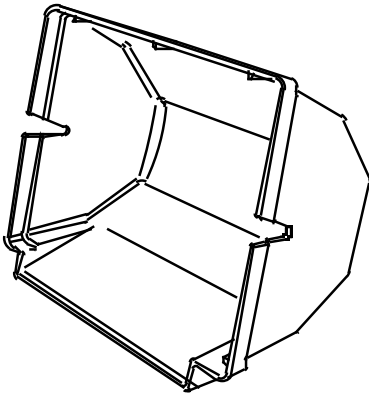

1. Position the back of the lid so that the rear holes are in line with the hinge struts on the back of the grill bottom.
2. Gently set the grill lid onto the grill bottom.

3. Hold the lid to align the hinge holes.
4. Insert a hinge pin through the hinge hole in the lid and into the hole in the bottom hinge strut.
5. After the hinge pin is in place, insert a hair pin through the hole of the hinge pin to secure it.

HINT: There is an air space between the back of the lid and the grill bottom where you can install the pins.

6. Repeat for the opposite side.

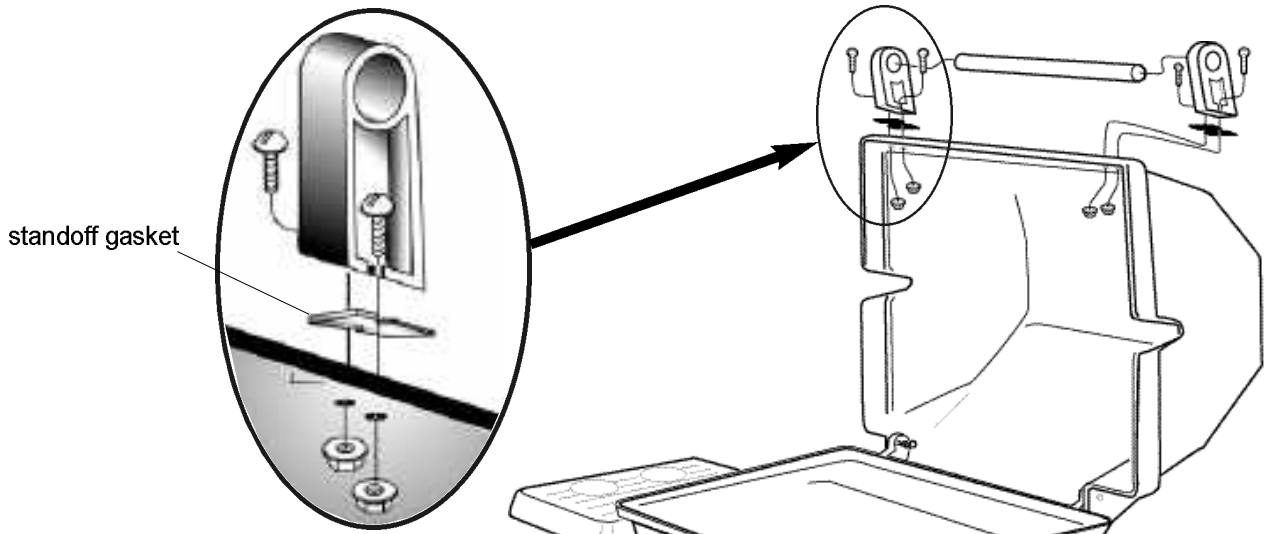
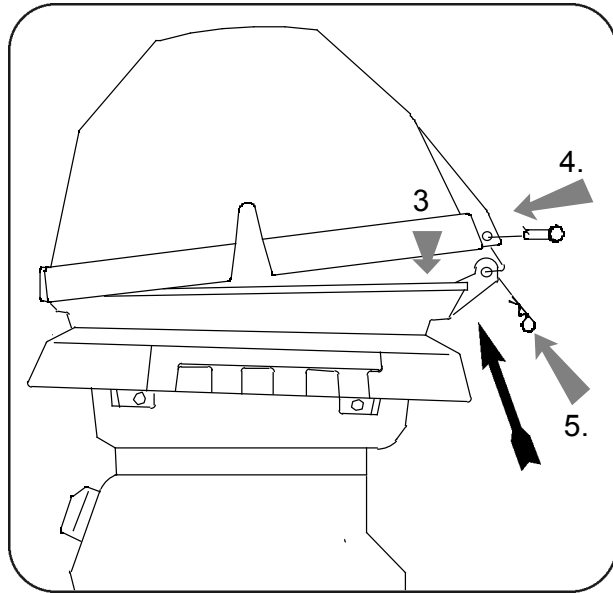

7. Raise the lid to attach the front handle.
8. Attach a handle standoff to the front of the grill lid, as shown.
9. Insert one end of the handle into the hole of the standoff.
10. Place other standoff onto handle and while holding the handle in place assemble the opposite standoff to the lid in the same manner.

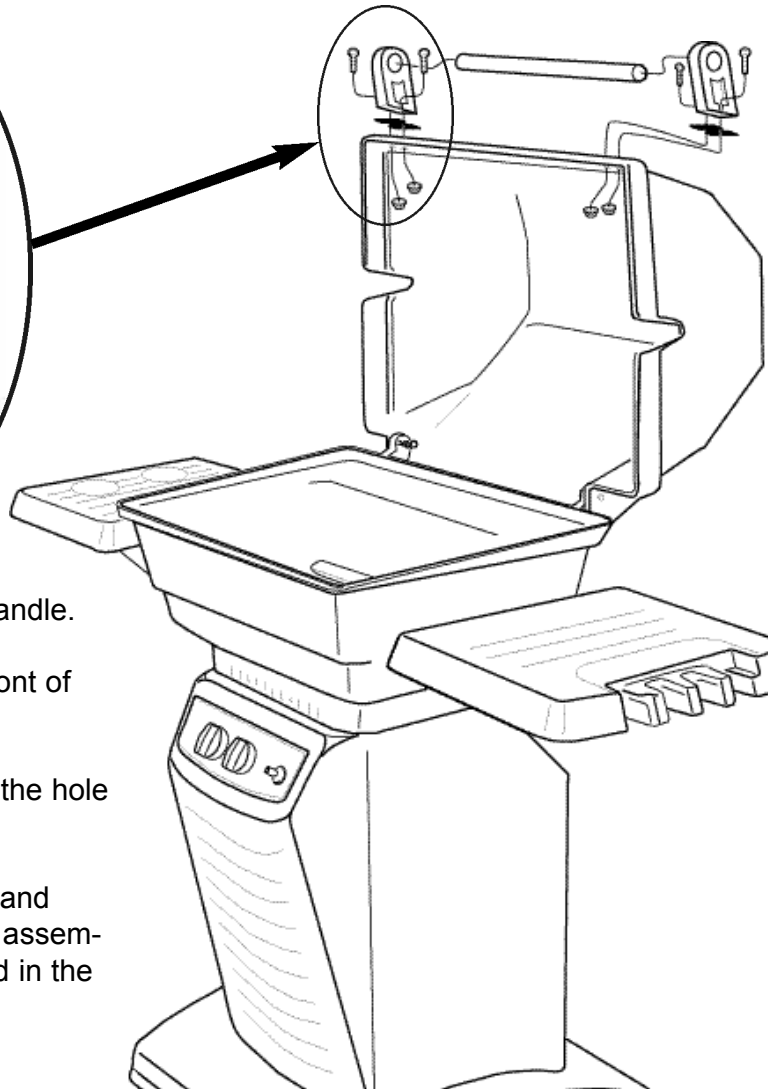

Assembly Instructions • Installing the Internal Grill Parts.

No tools are needed.

Locate these parts:

rock grate
(1)

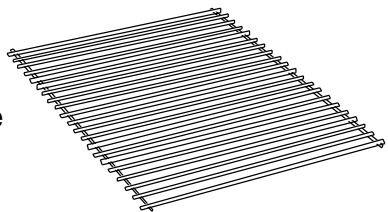

ceramic
briquettes
(1 box)

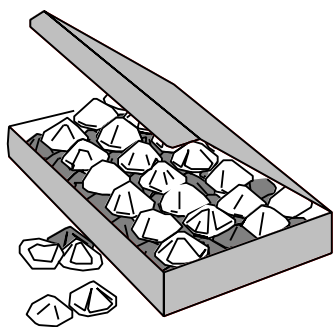

cooking grid
(1)

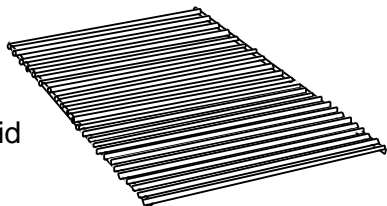

warming
rack
(1)

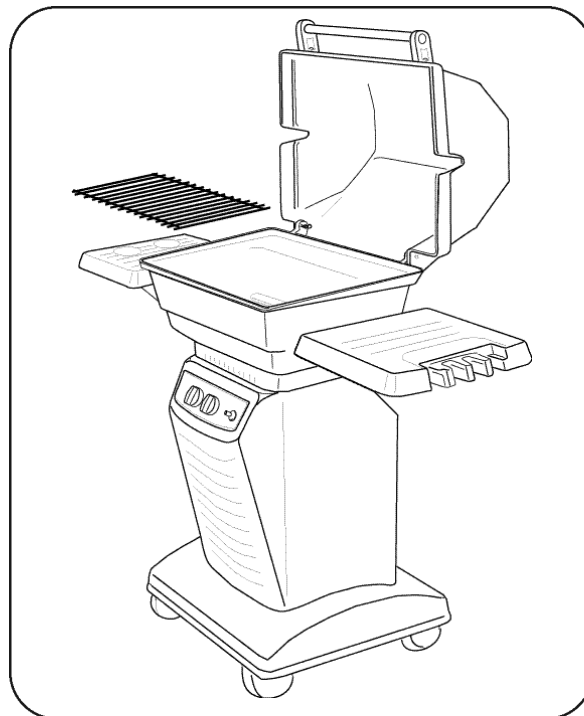
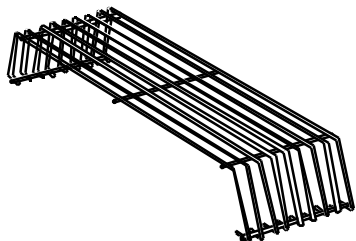

1. Place the single rock grate into the grill bottom.

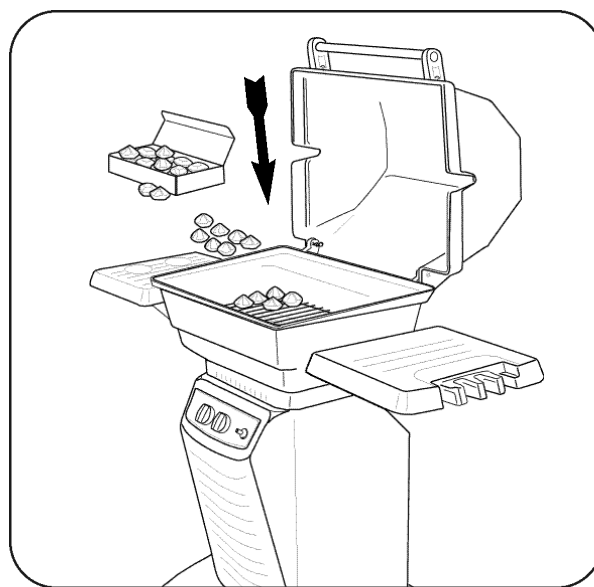

2. Open the package containing the ceramic briquettes and place them on the rockgrate.

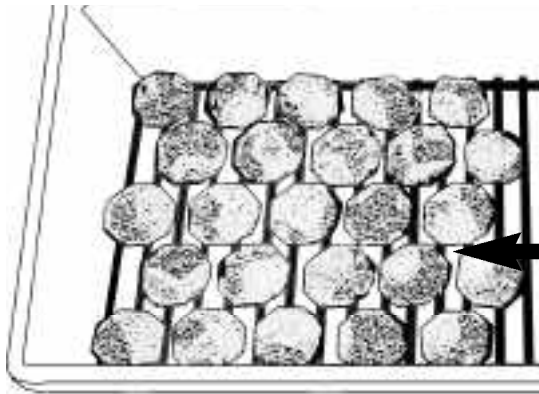

3. It is important to properly arrange all the ceramic briquettes onto the rock grate to allow for good air flow during use.

NOTICE THE SPACING:

The proper amount of briquettes are supplied and there is no need to add more. Some space between the briquettes is necessary.

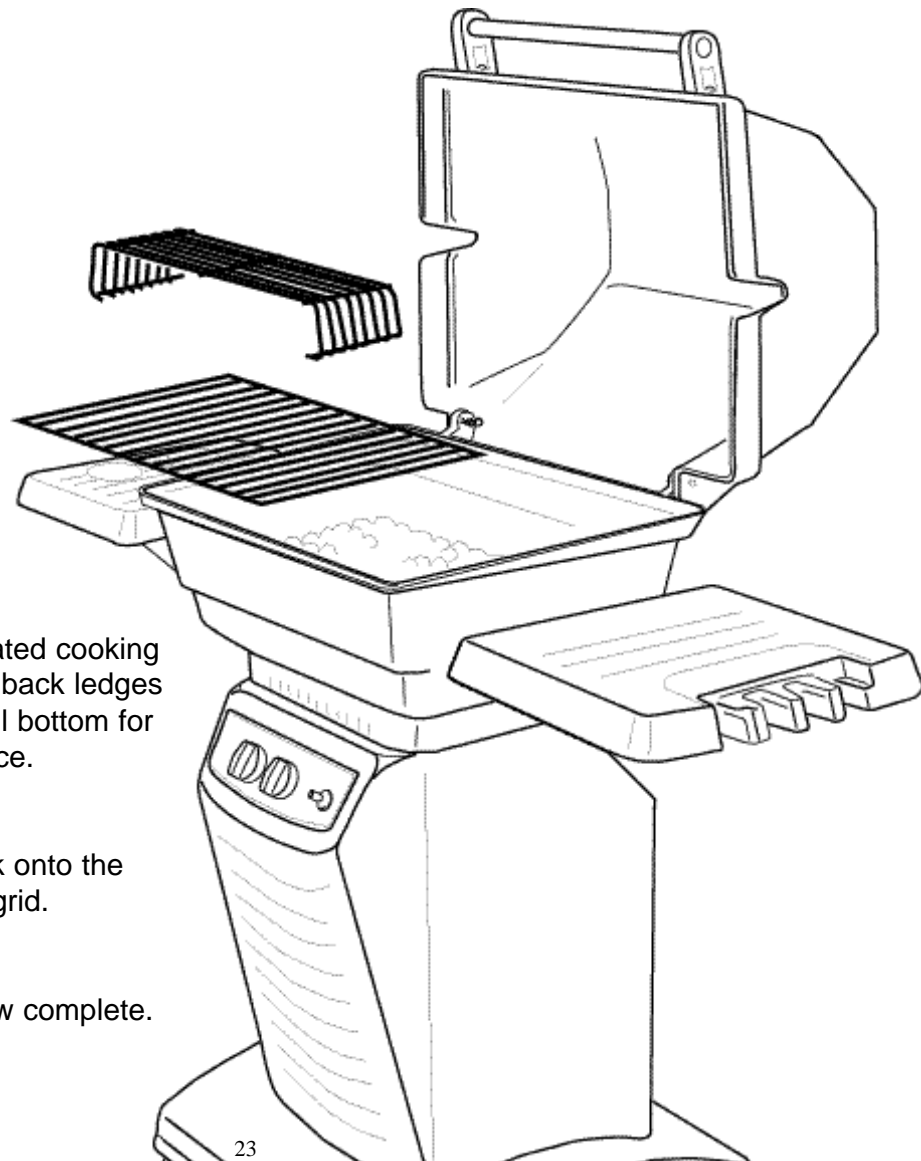

4. Set the porcelain coated cooking grid on the front and back ledges formed inside the grill bottom for a level cooking surface.

5. Set the warming rack onto the back of the cooking grid.

The grill assembly is now complete.

Installing an L.P. Gas Cylinder.

items needed:

L.P. gas cylinder
(1 FILLED)
**(not included
with grill kit)**

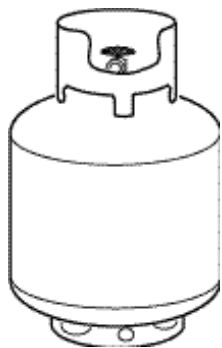

WARNING:

Connect the L.P. cylinder to the grill outdoors only.

2. Read and follow all directions on the cylinder and fuel hose safety tags.
3. Working behind the grill, temporarily remove the X-brace retainer wire from the pillar.
4. Set the filled L.P. gas cylinder into the large round opening in the grill base.

Connecting an L.P. Gas Cylinder.

1. The top knob on the supply cylinder must be closed. See that the top cylinder knob is turned clockwise to a full stop.
2. Check that all the grill burner knobs are turned off.
3. Remove the protective caps from the cylinder valve and coupling nut, if present.
4. Hold the regulator in one hand and insert the nipple into the valve outlet. Be

1. Obtain a filled L.P. gas cylinder.

REMINDER: An L.P. gas cylinder is not included in the 4000 series grill. Please refer to pages 6 and 7 of the manual for the correct cylinder specifications.

(Behind and below the grill bottom.)

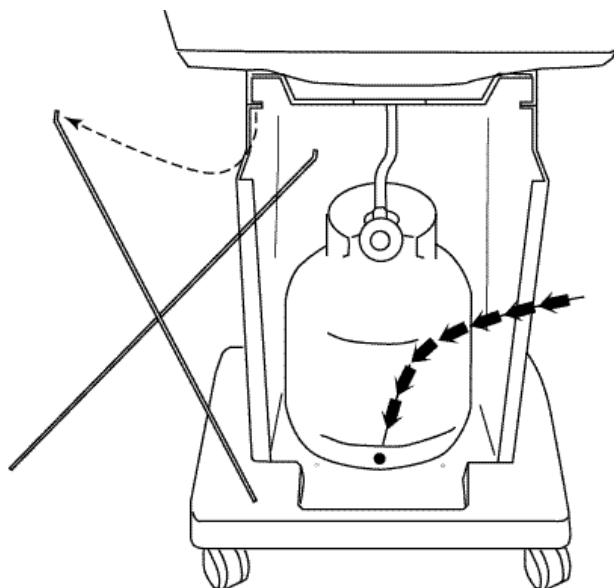

Remove the Brace to Install Cylinder



Connecting the Regulator to Cylinder

Connecting an L.P. Gas Cylinder.

sure the nipple is centered in the valve outlet. The coupling nut connects to the large outside threads on the valve outlet. Use care not to cross thread the connection.

5. Hand tighten the coupling nut clockwise until it comes to a full stop. Tighten by hand only. Do not use tools.
6. **CAUTION:** In the connection process, the grill side of the connection will seal on the back check in the valve, resulting in a slight resistance. The connection requires about one-half to three-quarters additional turn to complete the connection.

NOTE: If you cannot complete the final connection, disconnect the regulator and repeat steps 4 through 6. If you are still unable to complete the connection, do not use this valve and regulator.

7. Make sure the hose has no kinks or sharp bends and clears any areas that will become hot during use. Never put strain on the hose where it joins a fitting. The rubber fuel supply hose must not touch the bottom grill casting during use.
8. Before lighting grill check all connections for leaks using a mild soapy-water solution as directed in the "Leak Testing" section of this manual (page 27).
9. Replace the X-brace in the pillar as previously instructed.
10. Place the aluminum grease pan into the opening in the heat shield located beneath the grill bottom. During use the pan will catch hot grease drippings that could damage the fuel supply system. When needed the grease pan may be replaced with any 3 1/2" x 6" aluminum loaf pan available at most grocery stores.

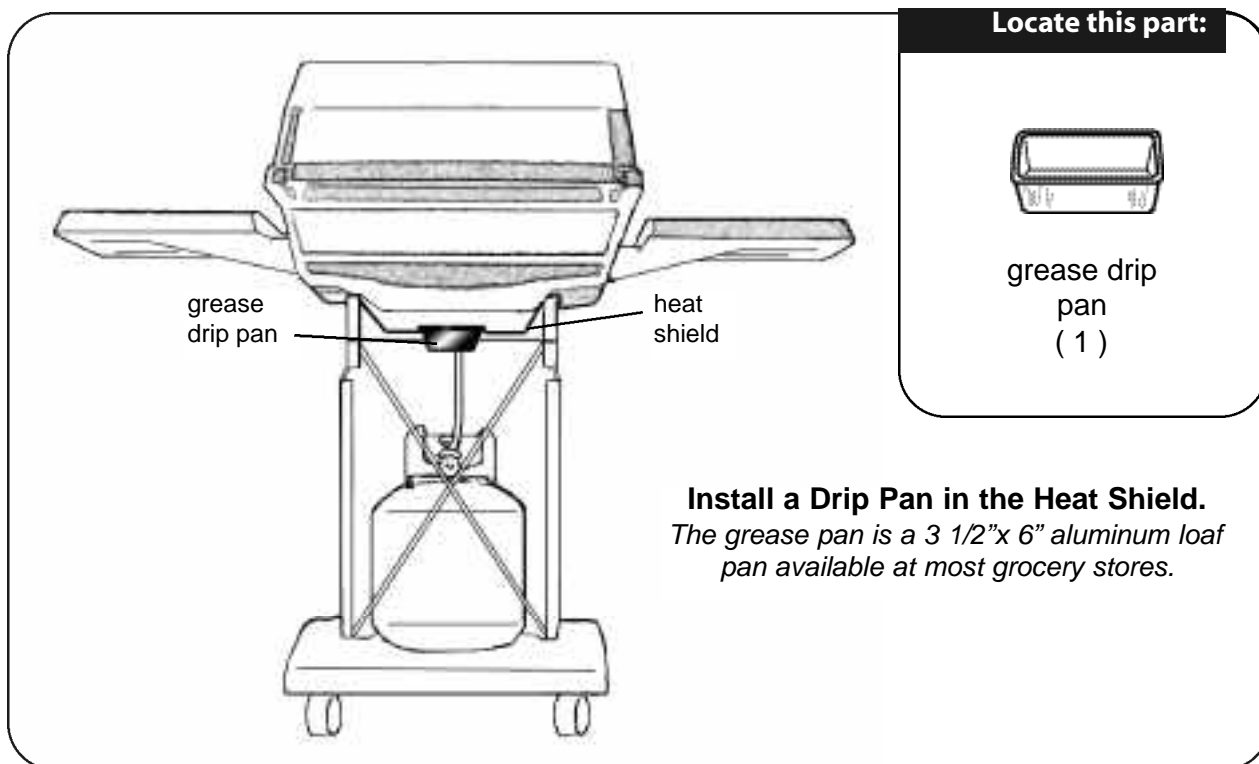

Model 4000 Series

Use and Care Directions

Chapter 3

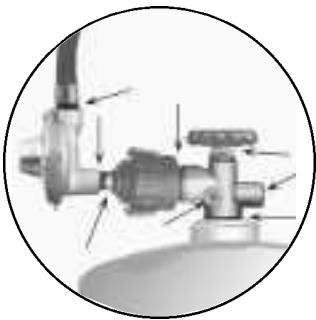

Leak Testing the Fuel Supply System



Lighting Instructions

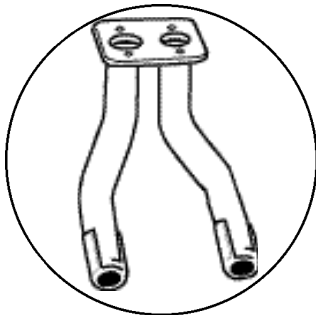

Replacement Parts

Leak Testing

DANGER

To prevent fire or explosion hazard:

- Do not smoke while performing a leak test.
- Do not permit any sources of ignition in the area when testing for leaks.
- Perform leak tests outdoors only.
- Never perform a leak test near a fire or flame.

How to Check the Fuel-Supply System for Gas Leaks

1. Mix a solution of equal parts mild detergent or liquid soap and water.
2. Turn off the burner-control knobs.
3. Turn the top knob of the fuel-supply cylinder counterclockwise one rotation to open.
4. Apply the soap solution to all connections of fuel-supply assembly.

If no soap bubbles appear, the grill is fine for use.

If bubbles form at the connections, there is a leak. In case of a leak, try tightening the joint. If necessary, replace the faulty part with a replacement part recommended by the manufacturer.

5. Turn off the knob on fuel-supply cylinder.
6. Turn on the burner-control knobs for a moment to release pressure in hose, then turn the control knobs back off.
7. Wash off soapy solution with cold water and towel dry.

WARNING! Do not attempt to repair the cylinder valve. If it becomes damaged, the cylinder must be replaced.

If you are unable to stop a leak, shut off the gas supply at the cylinder valve. Remove the cylinder from the grill. Call a gas appliance serviceman or L.P. gas dealer. Do not use appliance until the leak is fixed.

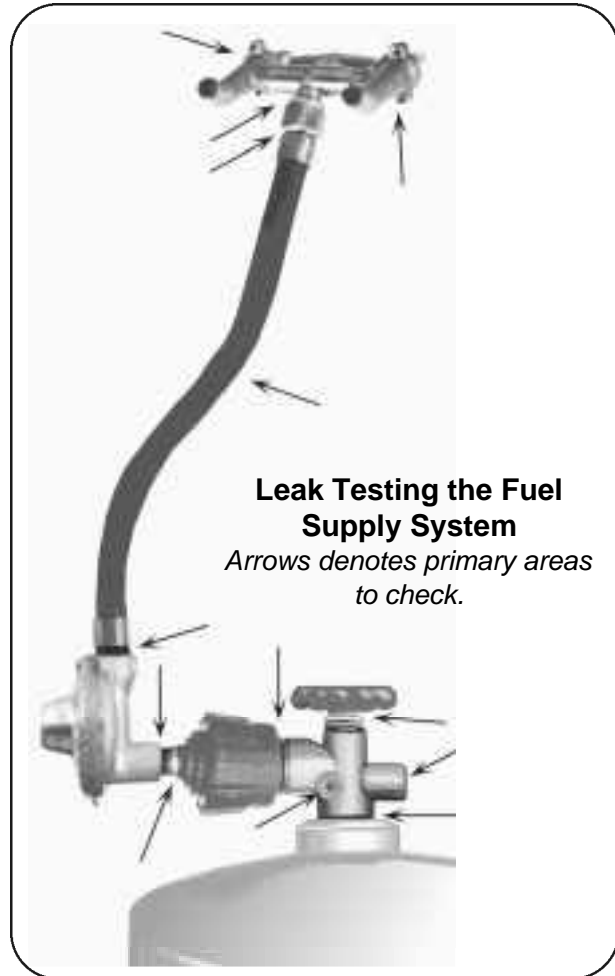

Perform a leak test each time the gas-supply cylinder is connected to the regulator. Leak test any time a part of the gas system is replaced. Perform a leak test at least once each year whether the L.P. gas supply cylinder has been disconnected or not.

Have a dealer check the cylinder for deterioration after 10 years, according to DOT regulations. Immediately replace cylinder if any is found.

IMPORTANT! Inspect the gas-supply hose regularly. If there are cuts, excessive abrasion, or wear, replace the hose prior to operating the appliance.

Use only the hose replacement specified in the parts list for your grill.

Lighting Instructions

IGNITER LIGHTING SYSTEM

The Igniter System consists of an igniter unit, a gas-collector box, one ceramic electrode, and lead wires. Gas is collected in the metal collector box located at the burner. When the igniter knob is turned, an electric spark is created at the ceramic electrode. The gas is then ignited by the spark.

To test: Watch the electrode tip inside the gas collector while activating the igniter. To avoid a possible shock, do not touch the burner or metal parts on igniter system while performing igniter test. A visible spark should jump from the electrode. The spark gap is set when the electrode is installed.

If there isn't a spark, check the lead wires and connections. The igniter wires should be kept away from the grill bottom. Also check that the ceramic electrode in the collector box are not broken.

Sometimes dirt and rust at and around the electrode can prevent an igniter spark. Clean them with a degreaser or warm soapy water, and dry. Remove rust from electrode tip and metal surfaces by lightly sanding with an emery cloth or fine-grain sandpaper.

LIGHTING INSTRUCTIONS

(Read all the steps before beginning.)

STEP 1. Check the burner venturi tubes for blockage from an insect nest (see, "CLEANING THE BURNER VENTURI TUBES").

STEP 2. Ensure that both of the burner-control knobs are in the OFF position.

STEP 3. **OPEN GRILL LID**

WARNING: Attempting to light the grill with the lid down could cause an explosion.

STEP 4. Go behind the grill and turn on the fuel supply valve. One counter-clockwise turn is generally enough to open the valve.

CAUTION: Do not stand with head or arms over the grill.

STEP 5. To light using the igniter:

Push in and turn the right burner control knob counter-clockwise to a high setting.

STEP 6.

Immediately press in the igniter button until you hear it click. Repeat four (4) to five (5) times if necessary. The burner should light.

STEP 7.

If the burner fails to light properly, turn the burner-control knob off. Also turn off the L.P. cylinder knob. Wait five minutes before attempting to light the burner again. This will allow time for released gas to disperse.

HINT: If the burner does not light after trying again, turn off burner-control knob, the L.P. cylinder knob and try match lighting the grill once the gas has cleared.

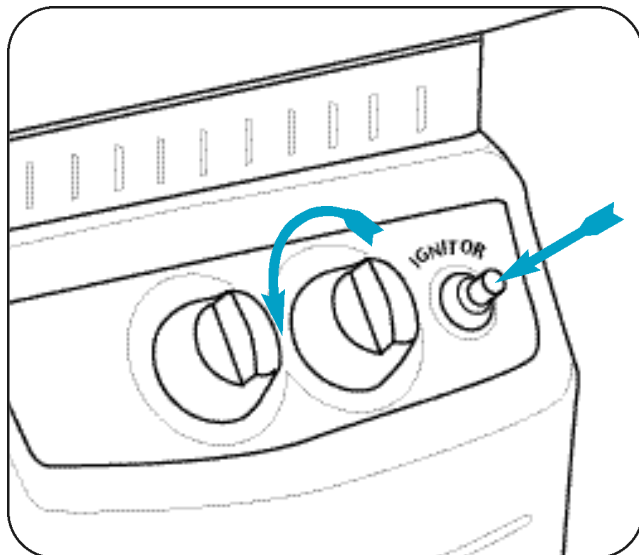

Operating the Control Knobs

Use the **RIGHT** burner gas control knob, **PUSH IN** and rotate counter-clockwise.

PRESS ON THE IGNITER BUTTON UNTIL IT CLICKS. Release and press again 4 or 5 clicks for burner to light.

Lighting Instructions

MATCH LIGHTING

IMPORTANT! The match-lighting hole is found under the front right corner of the grill bottom. When match lighting the grill, use the gas-control knob on your **RIGHT-HAND** side (closest to the match-lighting hole).

Repeat steps 1 to 4 of "Lighting Instructions."

STEP 5. To match light: push down and turn the **RIGHT** burner control knob counter-clockwise to the high setting.

STEP 6.

IMMEDIATELY strike a long wooden match and position the burning match through match-lighting hole in the grill bottom. Extend the flame near a burner port in the bottom edge of the burner. The burner should light.

To light the other side of the burner, press in and turn the opposite control knob. The flame will track around the burner. Allow grill to preheat with the grill lid closed for five minutes before cooking.



Locating the Match Lighting Hole

The match lighting hole is located beneath the lower right corner of the grill-bottom casting.

CAUTION: Do not touch any hot grill parts. The outside of the grill bottom becomes very hot during use. It may be necessary to use protective gloves.

HOW TO SHUT OFF THE GRILL

STEP 1. Turn the burner-control knob(s) off. The burner flame will go out.

STEP 2. Turn off the top L.P. cylinder valve by turning the knob in a clockwise direction until it stops.

IMPORTANT: Always have the gas shut off at the L.P. cylinder valve when the grill is not in use. The L.P. cylinder has a leak detection feature which will restrict the amount of gas flow to the burner if the tank shut-off valve has not been turned off prior to the next use.

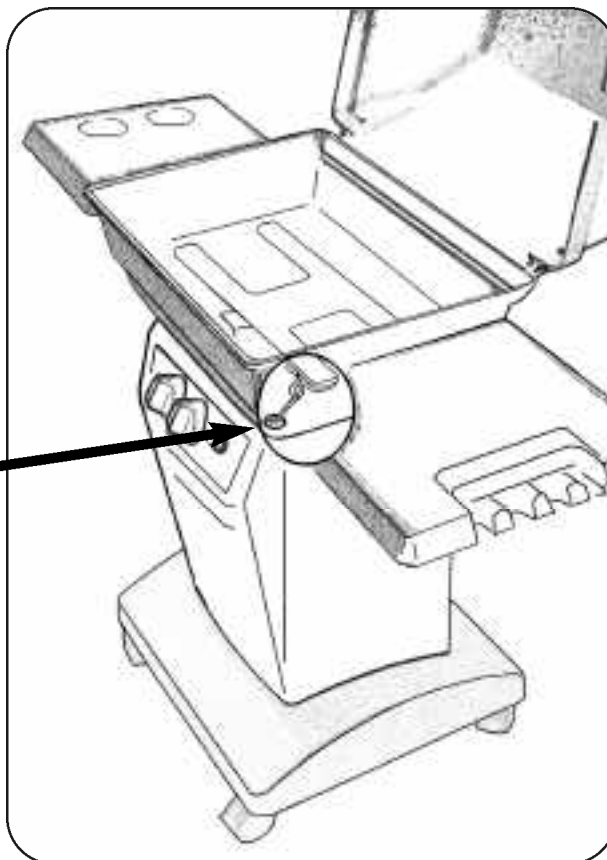

Using Your Gas Grill

TO BREAK IN A NEW GRILL

Before using it for the first time; operate the grill with lid closed on a low setting for about 15 minutes. This will help burn away oil and the smell of new paint. After the oil has burned away, check the burner flame.

BURNER'S FLAME

Keep the grill lid closed and the grids in place. Inspect the burner's flame by carefully looking below and through the air-supply openings in the grill bottom.

A good flame should be blue with some yellow tip coming from the burner holes. Some yellow tips on flames up to 1" in length are acceptable as long as no carbon or soot deposits appear.

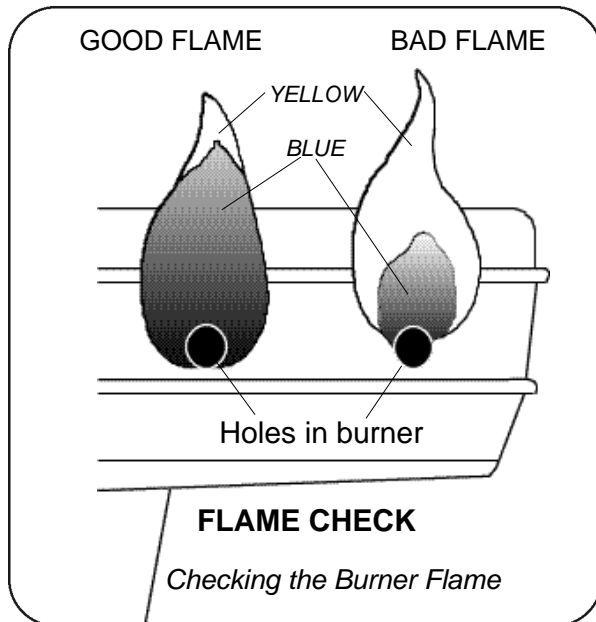

If flames are excessively yellow and irregular, the oil residue may not be completely burned off, or the venturi may not be properly positioned over the orifice(s). Allow grill to cool before repositioning venturi over valve.

After a grill has been in use for a while it may begin to have a more yellow flame. A build up of food deposits, fats, or cooking seasonings can cause yellowing of flames.

Try cleaning the burner to remove built-up residue. Check for clogged burner holes or blocked venturi tubes.

Regular use of your grill will actually help keep it operating more smoothly. It is not unusual for similar units to heat a little differently.

CONTROL SETTINGS

The high flame setting is for quick searing of meat. Sear foods, then finish cooking on a lower setting.

A medium setting works best for cooking steaks, pork chops, and hamburgers.

The lowest setting works well for all roasts and rotisserie foods. Even thick steaks, when seared on a high setting first, will have a better texture and be more juicy cooked on low.

DUAL BURNER COOKING SYSTEM

The grill's burner may be operated to cook on either side or both sides at once. This allows for various styles of cooking.

1. Use a direct heat source when browning meat or cooking hot dogs and hamburgers. Check the food often.

2. Cook large-size foods (such as roasts, turkey, or duck) on a low, direct heat. Place food and water in foil pan with corrugated bottom, adding water as needed.

3. If doing skillet or stir-fry cooking, limit the amount of oil and direct heat used.

4. Cook foods that burn easily over an indirect heat. Light one side of the burner and place the food on the other side for cooking. The food will cook slower but should be more tender. This method of cooking also reduces grease flare-up. Add a small pan of water to help keep meat moist, replace the water as needed.

5. Casseroles can be cooked in oven-proof or foil pans using indirect heat.

6. Cook two foods at once using different settings.

7. To add smoked flavor, try adding wood chips in apple, mesquite, and hickory flavors.

Cleaning and Maintenance

COOKING TIPS

Coat cooking grids with cooking oil to prevent food from sticking. Preheat the grill with the lid closed about five minutes before cooking. Cook with lid down when possible. This will keep temperature even, conserve fuel, improve food's flavor, and lessen flare-ups.

Never leave cooking food unattended. Frozen meat and poultry should be thawed before cooking. Trim the excess fat. Frozen fish and vegetables will cook without thawing. However, placing frozen food onto very hot porcelain grids can crack the porcelain finish.

Add salt to food after cooking to prevent it from drying out. Brush naturally lean meat, poultry or fish with cooking oil or margarine.

Cook small pieces of tender foods in foil. Apply barbecue, tomato, or sugar-based sauces no sooner than the last ten minutes of cooking. Turn food with a long-handled spatula or tongs.

During operation, stand to side of grill when opening the grill lid. Lift lid handle slowly in case of a grease flare-up. Do not position any part of your body directly above the cooking area. Some flare-up is expected. It adds a smoky flavor and sears food, but a major grease fire can cause a potentially hazardous situation and damage the grill.

WHAT TO DO IN CASE OF A MAJOR GREASE FIRE,

follow these steps:

1. Turn the burner-control knob(s) to off.
2. Stay away from grill.
3. Allow the fire to burn itself out.
4. After the fire is out and the grill is cool, shut off the fuel supply valve at the fuel source.
5. Clean all parts.
6. Check for damage to the gas-supply hose, burner valve, and burner. On L.P. appliances also check the L.P. cylinder, L.P. cylinder valve, regulator and hose. If any of these parts are damaged, replace them with factory authorized parts before operating the appliance again.

CARING FOR YOUR GRILL

Regular care of your grill will help keep it operating properly. Cleaning or maintenance may be done only when the grill is cool and with the fuel supply turned off. Clean grill parts and tighten loose hardware as needed.

Do not put grill parts in a self-cleaning oven as the extreme heat could damage them. Do not use a combustible or flammable cleanser on grill. Do not use a commercial oven cleaner.

Always keep a small aluminum pan beneath the grill bottom to catch grease drippings during use. The grease pan is a 3 1/2" x 6" aluminum loaf pan available at most grocery stores. CAUTION: The grease pan and grill bottom become extremely hot during use. To avoid burns empty grease pan only when the grill is cool.

Cleaning and Maintenance

The small vent hole in the regulator must be kept clean of dirt and debris. Keep the gas-supply hose at least 3" away from any grill surface that becomes hot during use.

REGULAR CLEANING AND UPKEEP

After each cooking, shut the lid and turn control knobs to highest setting for 5 minutes to burn off grease drippings inside grill. Occasionally turn the ceramic briquettes over before lighting to burn off extra grease residue. Replace them with fresh ones if they become too saturated with grease.

Use a brass bristle brush on porcelain cooking grids. Wash cooking grids with a mild soap, a scrub brush and hot water. Use a mild soap and hot water to wash all other grill parts.

To refinish the outside of the aluminum grill castings, clean and then lightly sand with a fine sandpaper. Clean with a vinegar / water solution, and rinse with water. When dry, paint with a high-temperature paint following directions on paint-can label.

Inspect and clean the burner regularly. Remove grill components from the grill bottom necessary to get to the burner inside.

Because the burner is made of cast iron, rusting is to be expected. Use a wire bristle brush to clean the burner surface. A Burner Cleaning Kit has been provided and is attached inside the pillar wall just above the certification label. Use the tool's serrated tip to clear the ports of any blockage.

CLEARING THE BURNER VENTURI TUBES

Spiders and other insects are known to sometimes build homes inside a burner's venturi tubes. This can become a serious problem. A spider web or wasp nest inside the venturi tube can block gas flow and can cause a fire at the gas-control valve. Such a fire can cause operator injury and do serious damage to your grill. The venturi tubes have fine screens to discourage spiders and insects from building a nest inside. However, some very small spiders may spin webs inside the venturi tubes.

Inspect the venturi tubes if a blockage is suspected.

First, disconnect and remove the fuel source from the grill.

Next detach and remove the burner from grill bottom.

Insert a long pipe cleaner (about 20" long) inside the venturi tubes to loosen and remove blockages. Use care so as not to damage the screens inside the tubes. A high pressured stream of water may also be used.

If a blockage occurs inside the gas-control valve, located behind the control panel, it may be necessary to clear the valve orifices. Unscrew the orifices from rear of the gas-control valve. Wash the orifices and blow air through the small end holes.

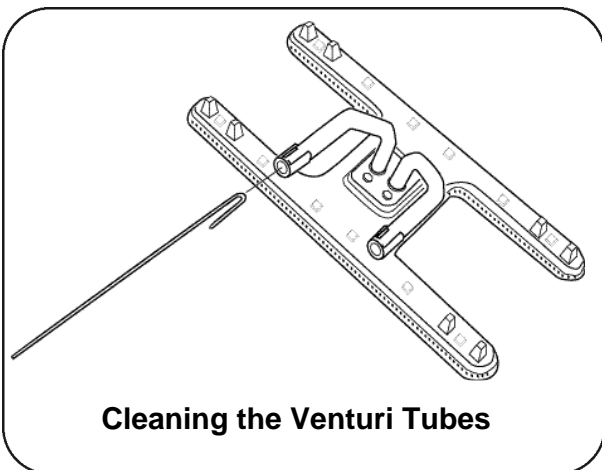

Cleaning the Venturi Tubes

Replace the orifices into the valve ends when they are dry.

WARNING! Never attempt to operate your grill without orifices in the valve. A serious and immediate fire hazard would result.

Replace the burner assembly into the grill bottom after it is clean. **IMPORTANT!** Make sure the valve orifices are inside venturi tubes. Secure burner to the grill bottom, and reconnect the igniter wires. Replace all other parts inside grill. Reconnect the fuel cylinder to grill. Inspect the condition and position of the gas-supply hose.

STORING AN L.P. GRILL

WARNING! Store an L.P. gas-supply cylinder outdoors in a cool area, out of direct sunlight, and away from people or pets.

Portable grills can be stored indoors without the cylinder. If leaving it outdoors, cover the grill for protection from weather.

OPTIONAL ELECTRICAL ACCESSORIES

If owner-supplied electrical accessories are used with grill (such as an electric rotisserie), follow specification statements included with the accessory. Do not allow cord to touch any hot surfaces that could melt the insulation.

IMPORTANT: If using an external electrical source, the installed appliance must be electrically grounded according to local codes or, in the absence of local codes, with the National Electrical Code, ANSI/NFPA 70 or the Canadian Electrical Code CSA C22.1.

Grounding Instructions. Use an appliance equipped with a three-prong grounding plug for your protection against shock hazard. It should be plugged directly into a properly grounded three-prong receptacle. Do not remove the grounding prong from a three-prong plug.

Long detachable power-supply cords or extension cords can also be used with care. The marked electrical rating of the cord set or extension cord should be at least as great as the electrical rating of the appliance. If the appliance is of the grounded type, the extension cord should be a grounding-type 3 wire cord. Use outdoor extension cords with a surface marked with suffix letters "W-A" and with a tag stating "Suitable for Use with Outdoor Appliances." Keep the connection to an extension cord away from water and off the ground. Arrange the cord so that it will not drape over the counter top or tabletop where it can be pulled or tripped over.

Do not clean any electrical product with a water spray or the like. Store electrical products indoors out of reach of children when not in use.

Model 4000 Series Replacement Parts

Replacement parts are available direct from our warehouse. Some components are not available preassembled and may be ordered separately. For convenience, the following parts list is provided along with a representation of the items listed. Charges for replacement parts and shipping may apply.

For warranty replacements, proof of ownership and date of purchase is required.

Please call 888-869-5454 to receive a return authorization number before returning any grill components.

To order parts call toll free in the USA: 888-869-5454.

You may also write to:

the Great Outdoors Grill Company®
7980 East American Drive
Joplin, Missouri U.S.A. 64804

PLEASE NOTE: All parts that meet the warranty requirement will be shipped at no-charge via the discretion of the Customer Service Department (ground shipments, US Mail, or Parcel Post ONLY). Any Special handling charges (i.e. Second Day, Overnight, etc.) will be the responsibility of the consumer.

Parts Enclosed

<i>quantity</i>	<i>description</i>	<i>part number</i>
1	Main Hardware Bag	AM000404
1	Hardware Bag "A"	
6	14 x 20 x 34" Bolt	AM000105
6	14 x 20 Hex Keps Nut	AM000904
1	Hardware Bag "B"	
4	14 x 20 x 3/4" Bolt	AM000105
1	Hardware Bag "C"	
8	14 x 20 x 34" Bolt	AM000105
8	14 x 20 Hex Keps Nut	AM000904
1	Hardware Bag "D"	
2	14 x 1 1/8" Hinge Pin	AM000908
2	Hairpin	AM000909
4	14 x 20 x 3/4" Bolt	AM000105
4	14 x 20 Hex Keps Nut	AM000904
2	Handle Gasket	AM000704

Parts Enclosed

<i>quantity</i>	<i>description</i>	<i>part number</i>
1	Grate	AF000203
1 package	Ceramic Briquettes	AQ000103
1	Cooking Grid	AF000104
1	Warming Rack	AF000304
1	Grill Lid	TOP350-BLK
1	Lid Handle	AP000102
2	Handle Standoffs	AZ000802
1	Aluminum Drip Pan	AI000302
1	X-Brace Cylinder Retainer	AF000404

Preassembled Components

1	Base Assembly
1	Pillar Assembly
1	Bottom/Burner Assembly
1	Right Side Table Assembly
1	Left Side Table Assembly

Breakdown of Preassembled Components

Bottom/Burner Assembly

quantity	description	part number
1	Bottom/Burner Assembly	
<i>consisting of:</i>		
1	Cast Iron Burner	AZ001505
1	Venturi Tube w/gasket	AZ000507
8	#8-32 x 7/16" Screw	AM000603
1	Bottom Grill Casting	BTM350-BLK
1	Collar	COLLAR C/P BLK
1	Heat Shield	AI000204
1	Forward Gasket	AM000911
2	Side Gasket	AM000910
4	1/4 x 20 x 1 1/4" bolt	AM000107
8	Speed Nuts	AM000906

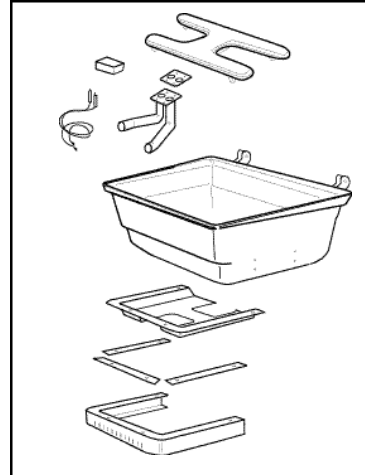

Pillar Assembly

1	Pillar Assembly	
<i>consisting of:</i>		
1	Pillar SF	AH000401
2	10 x 24 x 1/2" Bolt	AM000103
1	Valve/Regulator/Hose	AL000104
1	Push Button Igniter	AN000304
2	Control Knobs	AZ000704

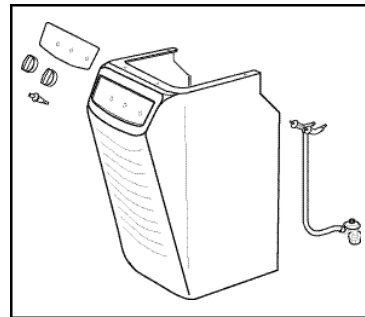

Side Table Assemblies

1	Right Side Table Assembly	
<i>consisting of:</i>		
1	R.H. Bracket	SDTBL BRKT R BLK
1	L.H. Bracket	SDTBL BRKT L BLK
1	Right Side Table (w/hooks)	AH000403
4	Screws	AM000206
1	Left Side Table Assembly	
<i>consisting of:</i>		
1	R.H. Bracket	SDTBL BRKT R BLK
1	L.H. Bracket	SDTBL BRKT L BLK
1	Left Side Table (cup holder)	AH000404
4	Screws	AM000206

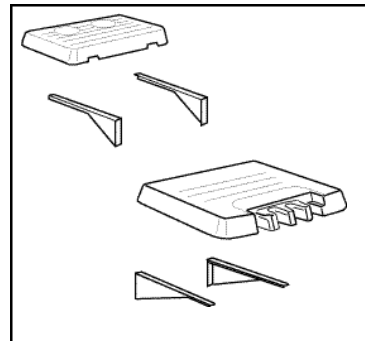

Base Assembly

1	Base Assembly	
<i>consisting of:</i>		
1	Base SF	AH000402
2	Locking Caster	AH000303
2	Caster	AH000305

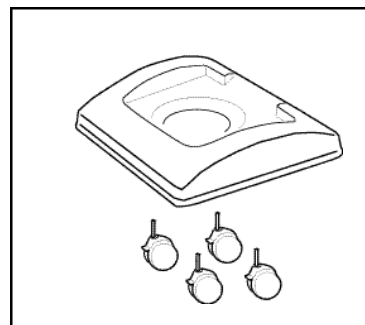

Outdoor Cooking

Recipes Chapter 4

BEEF

FLAVORFUL FLANK STEAK

1 beef flank steak (about 2 pounds)
3 tablespoons ketchup
1 tablespoon vegetable oil
1 tablespoon chopped onion
1 teaspoon brown sugar
1 teaspoon Worcestershire sauce
1 garlic clove, minced
1/8 teaspoon pepper

Place flank steak in an 11-in. x 7-in. x 2-in. glass dish. Combine remaining ingredients; pour over meat.

Cover and refrigerate for at least 4 hours. Remove meat, discarding marinade.

Grill over hot grill until meat reaches desired doneness, about 4 minutes per side for medium, 5 minutes per side for medium-well.

Slice into thin strips across the grain to serve.
Yield: 8 servings.

BETTER BURGERS

1 pound ground beef or turkey
4 teaspoons prepared horseradish
2 teaspoons Dijon mustard
1 teaspoon paprika
1/4 teaspoon pepper
1/8 teaspoon salt, optional
4 hamburger buns, split

In a bowl, combine the first six ingredients; mix well. Shape into four patties. Grill until desired doneness. Serve on buns. **Yield:** 4 servings

DISAPPEARING SHISH KEBOBS

1/2 cup ketchup
1/2 cup sugar
1/2 cup soy sauce
1 teaspoon garlic powder
1 teaspoon ground ginger
2 pounds boneless beef sirloin steak
(1-1/2 inches thick),
cut into 1-1/2-inch cubes
1/2 fresh pineapple, trimmed and
cut into 1-inch chunks
2 to 3 small zucchini, cut into 1-inch chunks
1/2 pound whole fresh mushrooms
(medium size work best)
1/2 pound boiling onions, peeled
1 large green or sweet red pepper,
cut into 1-inch pieces

Combine first five ingredients; toss with beef. Cover and refrigerate overnight. Drain beef, reserving marinade. Thread meat, pineapple and vegetables alternately on long skewers.

Cook on a hot grill 15-20 minutes, turning often, or until meat reaches desired doneness and vegetables are tender.

Simmer the marinade in a small saucepan over low heat for 15 minutes. Remove meat and vegetables from skewers; serve with marinade.
Yield: 6-8 servings.

HINT: Soak wooden or bamboo skewers in water about a half hour prior to cooking.

POULTRY

GRILLED CHICKEN

1 broiler/fryer chicken
(3-1/2 to 4 pounds), quartered
1/4 cup vinegar
1/4 cup butter or margarine
1/4 cup water
1/4 teaspoon dried thyme
1/4 teaspoon oregano
1/4 teaspoon rosemary
1/4 teaspoon garlic powder
1/8 teaspoon salt
1/8 teaspoon pepper

Place chicken in a shallow glass dish. In a small saucepan, combine all remaining ingredients; bring to a gentle boil. Remove from the heat. Pour over chicken. Cover and refrigerate for 4 hours, turning once. Drain and discard marinade. Grill chicken, covered, over medium heat for 30-40 minutes or until juices run clear. **Yield:** 4 servings.

TASTYTURKEY

1/4 cup soy sauce
1/4 cup vegetable oil
1/4 cup apple juice
2 tablespoons lemon juice
2 tablespoons dried minced onion
1 teaspoon vanilla extract
1/4 teaspoon ground ginger
Dash of garlic powder
Dash of pepper
2 turkey breast tenderloins
(about 1/2 pound each)

In a large resealable plastic bag or shallow glass dish, combine the soy sauce, oil, apple juice, lemon juice, onion, vanilla, garlic powder and pepper. Add turkey; seal or cover and refrigerate for at least 2 hours. Discard marinade. Grill turkey, covered, over medium heat for 8-10 minutes per side or until juices run clear. **Yield:** 4 servings.

PORK

BEST PORK RIBS

3 pounds country-style pork ribs
1/2 teaspoon garlic salt
1/2 teaspoon pepper
1 cup ketchup
1/2 cup packed brown sugar
1/2 cup honey
1/4 cup spicy brown mustard
2 tablespoons Worcestershire sauce
1-1/2 teaspoons liquid smoke, optional

Place ribs in a large kettle or Dutch oven; sprinkle with garlic salt and pepper. Add enough water to cover. Cook on your kitchen stove and bring to a boil. Reduce heat; cover and simmer for 1 hour or until juices run clear and ribs are tender; drain. Meanwhile, combine the remaining ingredients. Remove ribs from kettle to barbecue the ribs. Grill ribs, uncovered, over medium heat for 10-12 minutes, basting with sauce and turning occasionally. **Yield:** 4 servings.

HMM - HMM HAM STEAK

1-pound ham steak, 1/2 inch thick
1 tablespoon Dijon mustard
1 tablespoon honey
1 tablespoon apricot preserves

Cut outer edge of fat on ham diagonally at 1-inch intervals to prevent curling (do not cut into ham). Mix mustard, honey and preserves. Grill ham uncovered 4 to 6 inches from medium-high heat 4 minutes. Turn ham; brush with mustard mixture. Grill 4 minutes longer. Turn ham; brush with remaining mustard mixture. Grill about 2 minutes longer or until heated through. **Yield:** 4 servings.

GRILLED HAM & SWISS SANDWICHES

1/4 cup butter, softened
2 tablespoons horseradish mustard
2 tablespoons chopped onion
2 tablespoons poppy seed
6 ounces thinly sliced ham
6 ounces sliced Swiss cheese
6 sandwich buns

Mix butter, mustard, onion and poppy seed. Spread mixture on both halves of each bun; layer a slice of Swiss cheese and several ham slices between halves. Wrap each sandwich in foil and grill for 20 minutes. Serve warm. **Yield:** 6 servings.

FISH / SEAFOOD

SHRIMP COMBO PACKETS

- 4 cups peeled potatoes (about 1-1/4 lbs.), sliced 1/8-inch thick
- 1 cup sliced leeks or mild onions
- 1 cup chopped plum tomatoes
- 20 jumbo shrimp (about 1 lb.) peeled and deveined
- 4 Tablespoon butter
- 2 teaspoon dill weed, crushed
- 1 teaspoon garlic powder
- 1 teaspoon salt
- 1/2 teaspoon ground black pepper

On work surface, place 4 sheets of heavy-duty or doubled aluminum foil each about 20 inches long. In the center of each, arrange 1/2 cup potatoes, overlapping slightly; top with 1/4 cup each leeks and tomatoes and 5 shrimp.

Dot with 1 tablespoon butter; sprinkle with 1/2 teaspoon dill weed, 1/4 teaspoon garlic powder, 1/4 teaspoon salt and 1/8 teaspoon black pepper. Arrange remaining potatoes over shrimp, overlapping slightly.

Bring long sides of foil together over mixture, allowing space for heat circulation and expansion; fold down to seal. Fold up short ends; crimp to seal. Place on grill. Cook until potatoes are tender and shrimp are cooked, approximately 20 minutes on the grill. Carefully lift pouch from grill and place in serving dish. Open carefully, allowing steam to escape.
Yield: 4 servings

SUPER SALMON

- 1-1/2 cups packed brown sugar
- 6 tablespoons butter or margarine, melted
- 3 to 6 tablespoons lemon juice
- 2-1/4 teaspoons dill weed
- 3/4 teaspoon cayenne pepper
- 1 salmon fillet (about 2 pounds)
- Lemon-pepper seasoning

In a small bowl, combine the first five ingredients; mix well. Remove 1/2 cup to a saucepan; simmer until heated through. Set aside remaining mixture for basting. Sprinkle salmon with lemon-pepper. Place on grill with skin side down. Grill, covered, over medium heat for 5 minutes. Brush with the reserved brown sugar mixture. Grill 10-15 minutes longer, basting occasionally. Serve with the warmed sauce.
Yield: 6-8 servings.

SIDE DISHES

RICE ON THE SIDE

- 1-1/3 cups uncooked instant rice
- 1/3 cup sliced fresh mushrooms
- 1/4 cup chopped green pepper
- 1/4 cup chopped onion
- 1/2 cup chicken broth
- 1/2 cup water
- 1/3 cup ketchup
- 1 tablespoon butter or margarine

In a 9-in. round aluminum foil pie pan, combine the first seven ingredients. Dot with butter. Cover with heavy-duty foil; seal edges tightly. Grill, covered, for 14 to 15 minutes or until liquid is absorbed. Fluff with a fork and serve immediately. **Yield: 6 servings**

AU GRATIN POTATO POUCHES

- 4 cups frozen O'Brien potatoes (16 ounces)
- 1 tablespoon vegetable oil
- 1/2 teaspoon seasoned salt
- 3/4 cup shredded Cheddar cheese (3 ounces)

Spray 18x13-inch foil with piece of heavy-duty aluminum foil with cooking spray. Place potatoes on foil. Drizzle with oil; sprinkle with seasoned salt. Wrap foil securely around potatoes. Grill on medium heat 30 minutes, turning once. Carefully open packet; sprinkle cheese over potatoes. Cover loosely and let stand for 4 to 5 minutes or until cheese is melted. **Yield: 6 servings.**

GRILLED BREADS

- 1 One pound loaf frozen bread dough, white or honey wheat, thawed
- 2 tablespoons olive oil
- Suggested Toppings for bread:**
Sliced fresh tomatoes with basil and grated Fontina cheese, OR Grilled onions, OR Fresh herbs and garlic, OR Grated Parmesan cheese and garlic, OR pizza sauce with grated mozzarella cheese and sliced olives, OR feta cheese and black olives

Divide dough into 4 equal pieces. Flatten each into a 6-inch round. Brush one side of each round with oil. Place oiled-side down on an oiled grid at medium heat. Cover and cook until browned and firm, about 5 minutes. Brush tops with oil; turn breads over. Top cooked side of bread with a suggested topping. **Yields: 4 servings.**

VEGETABLES

ONION BLOOM

- 1 Bermuda onion
- 1 tablespoon butter
- 2 teaspoons honey
- 1/2 teaspoon Worcestershire sauce

Peel onion; cut 1/2-inch slice from top of onion and leave root end. Cut onion from top into 8 wedges to within 1/2-inch of root end. Gently pull wedges apart. Brush 12-inch square of heavy-duty aluminum foil with vegetable oil. Place onion on square; loosely shape foil around onion. Sprinkle onion with butter, honey and Worcestershire sauce. Wrap foil securely around onion. Cover and grill onion at medium heat 50 - 60 minutes or until very tender. **Yields:** 1 serving

VEGETABLES ON A STICK

- 2 medium zucchini, cut into 1-inch slices
- 2 medium yellow summer squash, cut into 1-inch slices
- 1/2 pound whole fresh mushrooms
 - 1/3 cup olive or vegetable oil
 - 2 tablespoons lemon juice
 - 1-1/2 teaspoons dried basil
 - 1-1/2 teaspoons dried parsley flakes
 - 3/4 teaspoon garlic powder
 - 3/4 teaspoon dried oregano
 - 1/2 teaspoon salt
 - 1/8 teaspoon pepper

On skewers, alternately thread zucchini, yellow squash and mushrooms. In a bowl, combine the remaining ingredients. Brush some of the mixture over vegetables. Grill, uncovered, over medium heat for 10-15 minutes or until vegetables are tender, turning and basting occasionally with herb mixture. **Yield:** 4 servings.

HOW TO GRILL FROZEN VEGETABLES

Tear off a 36x18-inch piece of heavy-duty foil. Fold in half to make an 18-inch square. Fold up sides, using your fist to form a pouch. Place one 10-ounce package frozen vegetables in center of pouch. Season with salt and pepper; top with a pat of butter or margarine. Fold edges of foil to seal pouch securely, leaving space for expansion of steam. Grill over medium-hot until vegetables are cooked. Allow about 20 minutes for peas and other small vegetables; allow more time for larger vegetables. Turn the package of vegetables frequently.

DESSERTS

CINNAMON APPLES

- 4 medium tart apples, cored
- 4 teaspoons brown sugar
- 1/4 cup red-hot candies
- Vanilla ice cream, optional

Place each apple in the center of a piece of heavy-duty foil (12 in. square). Spoon 1 teaspoon sugar and 1 tablespoon red-hot candies into the center of each apple. Fold foil around apple and seal tightly. Grill, covered, over medium-hot heat for 30 minutes or until apples are tender. Carefully transfer apples and syrup to bowls. Serve warm with ice cream if desired. **Yield:** 4 servings.

SUMMER MEDLEY

- 3 medium ripe peaches, halved and pitted
- 1 cup fresh blueberries
- 2 tablespoons brown sugar
- 2 tablespoons butter or margarine
- 1 tablespoon lemon juice

Place each peach half, cut side up, on a double thickness of heavy-duty foil (12 in. square). Sprinkle each with about 2 tablespoons blueberries, 1 teaspoon of brown sugar, 1 teaspoon butter and 1/2 teaspoon lemon juice. Fold foil around the peaches and seal tightly. Grill, covered, over medium-low heat for 18-20 minutes or until the peaches are tender. **Yield:** 3 servings.

MEXICAN SMORES

- 1/2 cup creamy peanut butter
- 4 flour tortillas (8 inches)
- 1 cup miniature marshmallows
- 1/2 cup miniature semisweet chocolate chips
- Vanilla ice cream

Spread 2 tablespoons of peanut butter on each tortilla. Sprinkle 1/4 cup marshmallows and 2 tablespoons chocolate chips on half of each tortilla. Roll up, beginning with the topping side. Wrap each tortilla in heavy-duty foil; seal tightly. Grill, covered, over low heat for 5-10 minutes or until heated through. Unwrap tortillas and place on dessert plates. Serve with ice cream. **Yield:** 4 servings..



Manufacturers Limited Warranty





The Great Outdoors grill is guaranteed against broken or damaged parts at the time of purchase. Components are guaranteed against defect as follows: All cast-aluminum parts are warranted against burn through, rust, and structural failure excluding paint, neglect, or abuse, for 50 years from the date of purchase. The cast-iron burner (only) has a limited warranty of 10 years from date of purchase. If the burner should fail to operate during the warranty period, the Great Outdoors Grill Company® will prorate the cost of a replacement burner. All other parts carry a 5-year limited warranty, except paint, which is guaranteed to be free of defects for 90 days. L.P. cylinders (on propane models only) are warranted by the cylinder manufacturer.

This warranty is void if the grill collar, heat shield and heat gaskets are removed from the grill. The X-Brace retainer wire must always be kept in place for the warranty to be valid.

All parts that meet the warranty requirement will be shipped at no-charge via the discretion of the Customer Service Department (ground shipments, US Mail, or Parcel Post ONLY). Any Special handling charges (i.e. Second Day, Overnight, etc.) will be the responsibility of the consumer.

All warranty claims apply only to the original purchaser and require a proof of purchase verifying purchase date. Do not return parts to our address without first obtaining a return authorization number from our customer service. This service is available by calling toll free 888-869-5454.

This warranty may give you specific legal rights that vary by state.



the Great Outdoors Grill Company ®
7980 East American Drive
Joplin, Missouri U.S.A. 64804

www.gogrills.com